

WORLD METEOROLOGICAL ORGANIZATION

**INTERNATIONAL WORKSHOP ON
SATELLITE ANALYSIS OF TROPICAL CYCLONES**

HONOLULU, HAWAII, USA

(13 - 16 APRIL 2011)

FINAL REPORT

PREPARED BY CO-CHAIRS:

ANDREW BURTON and CHRISTOPHER VELDEN



CONTENTS

FORWARD	
GENERAL SUMMARY OF THE WORKSHOP.....	1
1. OBJECTIVES	1
2. ORGANIZATION OF THE WORKSHOP.....	1
3. IWSATC MAJOR FINDINGS.....	1
4. OUTCOMES AND RECOMMENDATIONS	6
APPENDICES:	
A. List of Participants.....	8
B. Workshop Agenda.....	13
C. Satellite Analysis Procedures in Operational Centers	
RSMC La Reunion.....	15
RSMC Miami.....	24
RSMC New Delhi.....	26
RSMC Tokyo.....	34
TCWCs in Australian.....	44
TCWC Jakarta.....	49
China Meteorological Administration.....	52
Hong Kong Observatory.....	59
Joint Typhoon Warning Center.....	62
NOAA National Environmental Satellite, Data, and Information Service (NESDIS).....	64

GENERAL SUMMARY OF THE WORK OF THE WORKSHOP

1. OBJECTIVES

The first WMO International Workshop on the Satellite Analysis of Tropical Cyclones (IWSATC) was organized by the WMO Tropical Cyclone Programme (TCP) in collaboration with the WMO World Weather Research Programme (WWRP), and the World Data Center (WDC) for Meteorology which is maintained by the National Oceanic and Atmospheric Administration (NOAA).

The main purpose of IWSATC is to increase the accuracy and reliability of satellite analyses of tropical cyclones (TCs) by sharing the latest knowledge and techniques amongst operational forecasters of the major warning centers and researchers. The organizers also envisaged the creation of a cross linkage between IWSATC and workshops of the International Best Track Archive for Climate Stewardship (IBTrACS). In this regard, the first IWSATC was held back to back with the second IBTrACS workshop.

The specific objectives of IWSATC are to:

- a) Describe the operational procedures of satellite analysis of TCs (including the use of the Dvorak technique) in the participating TC warning centers;
- b) Identify the differences in the procedures between the centers and their relevance to final TC intensity estimates and resulting Best Track data;
- c) Share recent developments in the satellite analysis of TCs, particularly the objective satellite-based TC analysis methods;
- d) Make recommendations on 1) how operational centers in common TC basins can better reconcile Dvorak procedural differences to derive more consistent TC estimates for real-time warnings, and among all TC basins for improved continuity in Best Tracks, and 2) how operational centers can optimally blend the emerging objective guidance methods with existing subjective methods in order to improve the overall satellite analysis of TCs as it relates to both operational warnings and the Best Track data.

2. ORGANISATION OF THE WORKSHOP

The IWSATC was held in the Asia Room of the Imin Center at the East West Center in Honolulu, Hawaii, USA, from 13 (p.m.) to 16 April 2011. The workshop was attended by 28 participants and was held back to back with the second IBTrACS, 11 – 13 (a.m.) April 2011.

2.1 Participants

The list of participants can be found in **Appendix A**.

2.2 Programme

The workshop agenda can be found in **Appendix B**.

3. IWSATC MAJOR FINDINGS

3.1 Satellite-based analysis of TCs: Current operational practices

A representative from each TC operational centre presented a summary of their current satellite analysis procedures. The presentations are available from the WMO/TCP website at <http://www.wmo.int/pages/prog/www/tcp/IWSATC.html> and the documents summarizing the procedures can be found at **Appendix C**. The following paragraphs summarize some of the more

significant satellite analysis differences between agencies that can lead to discrepancies in reported maximum wind speeds (V_{max}) during operations or in Best Track records.

3.1.1 Historically, the majority of reported TC V_{max} values by operational centers have been derived from application of the Dvorak analysis, by converting the Dvorak Current Intensity number (CI) directly to a maximum near-surface wind speed. Hence, the CI is commonly the primary original metric of intensity estimates. A degree of scatter in reported CI values between agencies is expected given the subjective nature of the Dvorak technique, and differences of ± 0.5 CI between analysts are common. While a reduction in the spread of CI is desirable, biases between agency estimates of V_{max} is of greater concern. One of the key objectives of the workshop was to identify existing biases between agencies and seek to better understand the causes. Referring back to the CI values for comparison of agency intensity estimates can be a first step towards reconciling analysis differences, since this circumvents the issues associated with use of different CI \rightarrow V_{max} tables (i.e. Koba et al. 1989) and different wind-averaging periods, as demonstrated in Nakazawa and Hoshino (2009).

3.1.2 USA-based agencies use a 1-minute averaging period for reporting V_{max} . The Chinese Meteorological Agency (CMA) reports a 2-minute wind, and the Indian Meteorological Department (IMD) reports a 3-minute wind. All the other agencies report a 10-minute average wind speed. The Japanese Meteorological Agency (JMA) uses the Koba et al. (1989) table for converting CI to V_{max} . All other agencies use the Dvorak (1984) CI \rightarrow V_{max} table, however agencies that report the WMO standard 10-min averaged V_{max} generally apply a wind-averaging conversion to reduce the 1-min wind value that has been traditionally associated with the Dvorak CI \rightarrow V_{max} table (Dvorak 1984, Atkinson and Holliday 1977)¹. Of the agencies represented at the workshop, all except Hong Kong Observatory (HKO; 0.9 conversion) use a 0.88 reduction factor. Following on from the recommendations of Harper et al. 2010, most agencies are planning to transition to a 0.93 conversion factor. Neither CMA nor IMD uses a fixed conversion factor but both agencies report that analysts occasionally subjectively reduce the reported V_{max} value to account for the difference in wind averaging periods. It is worth noting that the Koba CI \rightarrow V_{max} table uses 10-minute winds and hence there is no implicit conversion between wind averaging periods for V_{max} values reported by JMA. Table 1 provides a comparison between the CI \rightarrow V_{max} tables of Dvorak 1984 and Koba et al. 1989 (referred to hereafter as simply Koba) using a nominal conversion factor of 0.9 to convert the Dvorak CI \rightarrow V_{max} table to 10-minute winds. Table 1 demonstrates that even when the effect of different wind averaging periods is accounted for, significant differences in reported V_{max} will remain when comparing estimates from JMA with those from other agencies. The Koba relationship is similar to the Dvorak relationship across the middle of the intensity range, but assigns significantly higher(lower) wind speeds at low(high) CI numbers. Participants discussed these differences without reaching agreement on how to consolidate to a single CI \rightarrow V_{max} relationship.

3.1.3 The use of different wind averaging periods for reporting V_{max} can also have implications for the total number of TCs reported by an agency. Some agencies (e.g. the Australian Bureau of Meteorology, (BoM)) only include a system in their Best Track records if it has reached TC intensity, whilst other agencies use a lower intensity threshold for inclusion. Systems that have not reached a peak Dvorak intensity of T3.0 or greater are not systematically recorded by BoM, whereas JTWC will record a system with a peak Dvorak intensity of T2.5 as a TC. Where agencies use a lower threshold for including systems in the Best Track records, it should be possible to convert the reports to a common wind averaging period (or to a CI equivalent) to facilitate comparison.

10-minute winds (kts)

¹ As detailed in Harper et al. (2010), this traditional assumption is without a confirmed basis.

CI	Koba et al. 1989	Dvorak 1984
1.0	22	23
1.5	29	23
2.0	36	27
2.5	43	32
3.0	50	41
3.5	57	50
4.0	64	59
4.5	71	69
5.0	78	81
5.5	85	92
6.0	93	104
6.5	100	114
7.0	107	126
7.5	115	140
8.0	122	153

Table 1. Comparison of Koba et al. 1989 and Dvorak 1984 CI>Vmax tables. Dvorak (1984) values have been converted to 10-minute winds using a nominal conversion factor of 0.9 to enable a more homogeneous comparison.

3.1.4 Regional differences in the definition of a TC can also lead to discrepancies in the overall counts. For example, both Reunion RSMC and BoM employ definitions that require gale force winds to extend more than half way around the circulation near the center. This more stringent requirement will exclude some systems that other agencies would classify as TCs.

3.1.5 The Dvorak technique itself has been subject to a range of regional variations developed over time. Some of these were outlined in Velden et al. 2006. Others identified at IWSATC:

3.1.5.1 CMA outlined the use of a “simplified Dvorak technique” that represents a significant departure from the standard Dvorak (1984) technique (refer to <http://www.wmo.int/pages/prog/www/tcp/documents/ApplicationofDvorakTechniqueinCMA.doc> for details). The Enhanced IR (EIR) method is not employed. As a result of IWSATC, CMA will investigate the feasibility of introducing the standard Dvorak technique into operations.

3.1.5.2 IMD noted that they give preference to VIS imagery (when available) in their Dvorak analyses, as they consider that EIR analyses generally have a high bias in the North Indian Ocean (NIO). They also find that at the diurnally favorable time for marine convection during the early morning hours (around 21UTC for NIO longitudes), the NOAA/NESDIS Satellite Analysis Branch (SAB) and the JTWC estimates are generally higher than those of IMD. IMD considers that the improvement in cloud signatures that are often seen during this period is not reflected in the surface wind speeds, and hence they do not generally increase the intensity unless the improvement in cloud signatures persists into the less favorable hours following sunrise. These issues often lead to IMD indicating weaker NIO intensities than other agencies both operationally and in Best Tracks.

3.1.5.3 JMA reported that in addition to adopting the Koba CI>Vmax relationship for NWPacific TCs, they do not use the VIS method, instead relying solely on EIR analyses. JMA also detailed their use of an Early Stage Dvorak Analysis (ESDA) technique that considers systems in the T0-T2 range (refer to <http://www.wmo.int/pages/prog/www/tcp/documents/JMAoperationalTCanalysis.pdf>).

The ESDA technique is derived from elements of the initial classification rules for weak systems detailed in Dvorak 1984.

- 3.1.5.4 Many of the centers noted differences in their application of the Dvorak CI weakening rules. Specifically, Rule 9 states the final CI should be held for 12 hours under normal TC weakening conditions. However, some centers (eg. Reunion, BoM) have apply a 6-hour rule based on the work of Brown and Franklin (2004).². Other centers admitted to occasionally breaking this rule when rapid weakening was obvious. It is clear that a systematic application of the Dvorak weakening rules among agencies is lacking, and can lead to final intensity discrepancies.
- 3.1.5.5 JTWC and RSMC Reunion generally only use the Dvorak Shear pattern for weakening systems, finding that it overestimates the intensity during the development phase.
- 3.1.5.6 The use of the Dvorak Embedded Centre pattern is inconsistent among centers. Some (i.e. Reunion and BoM) rarely use it, finding that it is biased toward overestimating intensity³. Others (e.g. New Zealand) reported that they use it with caution, since it can be sensitive to fix position.
- 3.1.5.7 Handling of landfalling TCs remains problematic, in the sense of global continuity. Some agencies continue to analyze the Dvorak Tnums even after landfall (HKO, JMA). Others discontinue satellite analyses once a “significant” landfall is made, instead relying on other data sources and/or decay models. Another problematic issue identified is TCs that re-emerge from land back over open water, and how an agency re-initializes the intensity once this occurs. These landfall issues can influence the final Best Track intensities.
- 3.1.5.8 While TC Minimum Sea Level Pressure (MSLP) is not considered the most important operational intensity metric, it is recorded in Best Track records and some researchers have analyzed intensity trends in the Best Track records using MSLP. Historically, MSLP has predominantly been determined by the use of wind-pressure relations (i.e. $CI > V_{max} > MSLP$). Harper (2002) and Velden et al. (2006) documented the various range of wind-pressure relationships that have been employed over the years by operational centers. The use of different $V_{max} > MSLP$ relations over time and between agencies affects research that attempts to analyze intensity trends using MSLP as the intensity metric. Several agencies reported on the adaption of (or experimentation with) a new $V_{max} > MSLP$ relationship based on recent studies (Knaff and Zehr, 2007; Courtney and Knaff, 2009). Therefore, this adaptation could affect past TC analyses and/or future re-analysis for research that considers MSLP values/trends.

3.1.6 A major issue that was identified at the IWSATC regards the recording of “pure” Dvorak analysis results vs. adjusting the CI to reflect the final intensity estimate based on other data/observations. Especially, the use of passive microwave imagery (PMW) varies considerably among agencies. The use of PMW for center location is widespread, but some agencies (such as Reunion,) will on occasion use the PMW to actually adjust their Dvorak analyses. Some agencies adhere to a “pure” Dvorak CI as their final intensity estimate (i.e. Fiji). Still other agencies have satellite analysts whom may pass a Dvorak CI value to their TC analyst counterparts, whom may then adjust the final intensity estimate based on PMW or other data. This issue gets further complicated (especially in regards to past Best Track records) by the fact that the inter-agency

² BoM generally applies a 6-hour rule to all storms whereas Reunion applies it only for “small” systems.

³ As noted in Burton 2005, there is a rationale and a body of experience suggesting that Embedded Centre intensity estimates may have a bias toward overestimating intensity, particularly in the low latitudes of the southern hemisphere. It is notable that the two agencies that expressed the greatest reservations with the use of Embedded Centre patterns are agencies that operate in the low latitudes of the southern hemisphere.

availability and actual use of PMW (and other data such as scatterometer winds) is not well documented. In summary, the influence of emerging ancillary satellite data such as PMW and scatterometer winds on Dvorak CI values and final agency TC estimates is uncertain, but likely is a contributing element to inter-agency discrepancies.

3.2 Summary of objective techniques that were presented at the workshop

Representatives from the TC research community were called upon to present their latest work on development of objective satellite-based TC intensity estimation techniques. The presentations are available from the WMO/TCP website at <http://www.wmo.int/pages/prog/www/tcp/IWSATC.html>. The topics included: The Advanced Dvorak Technique (ADT), the Advanced Microwave Sounding Unit method (AMSU), the Automated Rotational Center Hurricane Eye Retrieval algorithm (ARCHER), the SATellite CONsensus approach (SATCON), passive microwave (PMW) applications, and the Multiplatform TC Surface Wind Analysis (MTCSWA). An introductory presentation was made by Mr Burton, Co-Chair of the Workshop. Its summary can be found in Appendix C. The following paragraphs summarize some of the more significant advances, findings, and uses of these emerging objective methods:

3.2.1 Of all of the objective techniques briefed, by far the most familiar to the operational representatives is the ADT. In fact, many of the agencies are already employing the ADT in their operational assessments. While this is seen as progressive and encouraged, it does raise an additional complication to interpreting regional differences in TC estimates. Specifically, this stresses the fact that some TC agency estimates are increasingly being reflected by final intensities that are not purely subjective Dvorak based (besides the NHC, which has relied on aircraft recon estimates for quite some time). Further complicating the picture is that the ADT has evolved, and continues to evolve, so that any impacts on intensity estimates that may have been influenced in part by real-time ADT values will be difficult to trace.

3.2.2 Other objective techniques such as SATCON and AMSU-based intensity estimates are being utilized by some of the agencies, but generally to a lesser degree. The delegates commented that more information and confidence guidelines are necessary from the algorithm developers, since these methods are less familiar to them than the ADT. This is an action item for the CIMSS researchers. JMA reported that they are developing objective MTSAT, PMW and AMSU analysis techniques.

3.2.3 The MTCSWA (Knaff et al., 2011) is a recently developed technique for objectively estimating the surface wind structure of TCs (i.e. wind radii). Many of the delegates were aware of the product and some centers are already using the MTCSWA, particularly for estimating the gale radius. However there was evidence that further training is required to prevent misuse. The major misuse is the assumption that the MTCSWA outputs an independent estimate of V_{max} . However, the displayed value is actually *input* to the MTCSWA from an external source, and should not be used as an independently-determined intensity estimate.

3.2.4 The delegates were very interested in a new method developed at CIMSS to objectively fix the centers of TCs from both IR and PMW imagery (ARCHER). This algorithm includes a component that also estimates TC intensity from PMW in certain situations (values are now fed to the ADT). The ARCHER is still a work in progress, but offers promise to those agencies looking for help/guidance in fixing TC centers to begin their analyses.

3.2.5 Delegates were pleased to learn of progress in efforts by the Naval Research Laboratory (NRL) to use computer vision and neural networks to derive TC intensities from passive microwave data. It is hoped that these efforts will eventually yield an objective estimate of TC intensity that is largely independent of the existing methods.

3.2.6 For reconciling Best Track discrepancies, the use of the ADT for an independent reanalysis seems plausible. Such efforts are underway at CIMSS.

3.2.7 The delegates stressed the need for further training in the application of objective techniques, and also the very useful PMW, particularly in the interpretation of method confidence levels, and ultimately for synthesis of the different estimates into a final intensity estimate. Documentation such as on-line references and perhaps even COMET modules was recommended.

3.2.8 In plenary discussion, there was general agreement that while the “pureness” of the Dvorak method and resulting derived CI values should be preserved on the record, the satellite analysts should be moving beyond the reliance on subjective Dvorak techniques towards a consensus approach utilizing all available intensity estimates. This is where the training and meeting together every so often as a community would pay dividends towards the goal of a global approach to satellite-based TC intensity analyses.

3.2.9 The researchers stressed the value in all countries sharing regional datasets of surface observations during current and historic TC events to enable improved validation of objective satellite methods.

4. OUTCOMES AND RECOMMENDATIONS

4.1 General Outcomes

4.1.1 Much greater interagency understanding. This workshop was an “eye opener” to many of the attendees.

4.1.2 Significant documentation of some of the causes of interagency differences in intensity estimates.

4.1.3 Important feedback from forecasters to developers of the emerging objective techniques.

4.1.4 Dialogue started between researchers and operational centres regarding the sharing of observational datasets.

4.2 Major Recommendations

4.2.1 Based on findings from the IWSATC, develop guidelines for the improvement of satellite analysis globally, with the idea to be presented by the co-Chairs at the Jakarta WMO TCC meeting.

4.2.2 Strongly encourage the sharing of national TC datasets to allow improved validation of existing satellite intensity estimation methods (to be followed-up by WMO).

4.2.3 Create and maintain a centralized web site hosted by WMO/TCP, with documentation summarizing regional differences in the satellite analysis of tropical cyclones, changes in local procedures, and availability/upgrades to advancing objective methods.

4.2.4 Expand training material focused on helping forecasters make optimal use of the available satellite-based intensity estimates.

4.2.5 Hold another WMO-sponsored IWSATC in two or three years, synchronized with the next IBTrACS meeting if possible, to measure progress and encourage further efforts towards consolidating reliability and accuracy in global satellite intensity estimates.

REFERENCES

- Atkinson, G.D., and C. R. Holliday, 1977: Tropical cyclone minimum sea level pressure/maximum sustained wind relationship for the Western North Pacific. *Mon. Wea. Rev.*, 105, 421-427.
- Brown, D.B. and Franklin, J.L. 2004. Dvorak TC wind speed biases determined from reconnaissance-based best track data (1997-2003). 26th Conf. on Hurricanes and Tropical Meteorology, Miami, FL, Amer. Met. Soc., 86-7
- Burton, A.D., 2005: Notes on the application of the Dvorak technique. Met. Note 225, Bureau of Meteorology, National Meteorological Library, GPO Box 1289, Melbourne, VIC, 3001, Australia, 8pp.
- Courtney, J, and J.A. Knaff, 2009: Adapting the Knaff and Zehr wind-pressure relationship for operational use in Tropical Cyclone Warning Centres, *Australian Meteorological and Oceanographic Journal*, 58, 167-179.
- Dvorak, V.F., 1984: Tropical cyclone intensity analysis using satellite data. NOAA Tech. Rep. NESDIS 11, National Oceanic and Atmospheric Administration, Washington, DC, 47 pp.
- Harper, B.A., 2002: Tropical cyclone parameter estimation in the Australian region - wind-pressure relationships and related issues for engineering planning and design - a discussion paper. Systems Engineering Australia Pty Ltd (SEA) for Woodside Energy Ltd, SEA Rep. No. J0106-PR003E, Nov, 83 pp. (available from Systems Engineering Australia Pty Ltd, 7 Mercury Ct, Bridgeman Downs, QLD 4035, Australia and on-line at <http://ugconnect.net/seng/download/Wind-Pressure%20Discussion%20Paper%20Rev%20E.pdf>).
- Harper, B.A., J. D. Kepert, and J. D. Ginger, 2010: Guidelines for converting between various wind averaging periods in tropical cyclone conditions. World Meteorological Organization, TCP Sub-Project Report, WMO/TD-No. 1555.
- Knaff, J.A., M. DeMaria, D. A. Molenaar, C. R. Sampson and M. G. Seybold, 2011: An automated, objective, multi-satellite platform tropical cyclone surface wind analysis. Submitted to *J. Appl. Meteor.*
- Knaff, J.A. and B.A. Harper, 2010: Tropical cyclone surface wind structure and wind-pressure relationships. In: Proc. WMO IWTC-VII, World Meteorological Organization, Keynote 1, La Reunion, Nov.
- Knaff, J.A., and R.M. Zehr, 2007: Reexamination of Tropical Cyclone Wind-Pressure Relationships. *Wea. Forecasting*, 22, 71-88.
- Koba, H., S. Osano, T. Hagiwara, S. Akashi, and T. Kikuchi, 1989: Determination of intensity of typhoons passing through the Philippine islands (in Japanese). *J. Meteor. Res.*, 41, 157-162.
- Nakazawa, T. and S. Hoshino, 2009: Intercomparison of Dvorak Parameters in the Tropical Cyclone Datasets over the Western North Pacific. *SOLA*, Vol.5, 033-036.
- Velden, C.S., and many co-authors, 2006: The Dvorak tropical cyclone intensity estimation technique: A satellite-based method that has endured for over 30 years. *Bull. Amer. Meteor. Soc.*, 87, 1195-1210.
- WMO 1993: Global guide to tropical cyclone forecasting. Tropical Cyclone Programme Report No. TCP-31, World Meteorological Organization, WMO/TD – No. 560, Geneva.
- WMO 2008: Guide to meteorological instruments and methods of observation. World Meteorological Organization, WMO-No. 8, 7th Ed, 681pp.

Appendix A: List of Participants

**INTERNATIONAL WORKSHOP ON
SATELLITE ANALYSIS OF TROPICAL CYCLONES**

HONOLULU, HAWAII, USA
(13 - 16 APRIL 2011)

LIST OF PARTICIPANTS

COUNTRY	PARTICIPANT	TEL., FAX, E-MAIL
AUSTRALIA	BURTON, Andrew Australian Bureau of Meteorology P.O. Box 1370 WEST PERTH, WA 6872 Australia	Tel.: 618 92 63 22 82 Fax: 86.21.6439.1966 E-mail: A.Burton@bom.gov.au
CHINA	LU, Xiaoqin Shanghai Typhoon Institute China Meteorological Adm. No. 166, Puxi Road Xuhui District SHANGHAI China	Tel.: 86.21.5489.6094 Fex: 86.21.6439.1966 E-mail: luxq@mail.typhoon.gov.cn
CHINA	YU, Hui Shanghai Typhoon Institute, CMA No. 166, Puxi Road Xuhui District SHANGHAI China	Tel.: 86.21.5489.6309 Fax: 86.21.6439.1966 E-mail: yuh@mail.typhoon.gov.cn
CHINA	ZHU, Xuesong Shanghai Satellite Remote Sensing and Application Centre No. 555, Xinbang Road MinHang District SHANGHAI, 201100 China	Tel.: 86.21.6492.1980 Fax: E-mail: xuesong_zhu@live.cn
CHINA	ZHANG, Ling National Typhoon and marine Forecast Center, CMA ZhongGuancun NanDajie 46 BEIJING 100081 China	Tel.: 86.10.6840.0456 Fax: 86.10.6840.0126 E-mail: zhangling@cma.cov.cn

Appendix A: List of Participants

FIJI	WAQAICELUA , Alipate Fiji Meteorological Service Private mail Bag 0351 Nadi Airport Fiji	Tel.: 6.796.724.888 Fax: 6.796.720.430 E-mail: alipate.waqaicelua@met.gov.fj
FRANCE	DUPONT, Thierry RSMC La Réunion METEO-FRANCE/DIRRE/CYC BP4 97491 SAINTE-CLOTILDE France	Tel.: 262.262.92.11.11 Fax: 262.262.11.48 E-mail: thierry.dupont@meteo.fr
HONG KONG, China	CHAN, Sai-tick Hong Kong Observatory 134A, Nathan Road KOWLOON, HONG KONG Hong Kong, China	Tel.: 852.2926.8434 Fax: 852.2375.2645 E-mail: stchan@hko.gov.hk
INDIA	GOYAL, Suman (Ms) India Meteorological Institute Satellite Meteorological Division Lodi Road NEW DELHI – 110003 India	Tel.: 91.11.2462.6021 Fax: 91.11.2469.9216 E-mail: suman.imd@gmail.com
INDIA	B. K., Bandyopadhyay India Meteorological Department Mausam bhavan, Lodi Road New Delhi India	Tel.: 91.11.2463.5664 Fax: 91.11.2464.3128 E-mail: bkbando1705@yahoo.co.in
INDONESIA	KHOTIMAH, Mia Khusnul (Ms) Indonesian Agency for Meteorology, Climatology and Geophysics Jalan Angkasa I No. 2 Kemayoran, Jakarta Pusat DKI JAKARTA 10720 Indonesia	Tel.: 62.21.6546.318 Fax: 62.21.6546.315 E-mail: m.khotimah@yahoo.com
JAPAN	KISHIMOTO, Kenji Japan Meteorological Agency National Typhoon Center 1-3-4, Otemachi Chiyodaku TOKYO 100-8122 Japan	Tel.: 81.3.3212.8341, ext. 3137 Fax: 81.3.3211.4923 E-mail: k-kishimoto@met.kishou.go.jp

Appendix A: List of Participants

JAPAN	KUNITSUGU, Masashi Japan Meteorological Agency National Typhoon Center 1-3-4, Otemachi Chiyodaku TOKYO 100-8122 Japan	Tel.: 81.3.3212.8341, ext. 3148 Fax: 81.3.3211.4923 E-mail: kunitsugu@met.kishou.go.jp
NEW ZEALAND	READY, Steve MetService P.O. Box 722 WELLINGTON 6140 New Zealand	Tel.: 64.4.4700.700 Fax: 64.4.4712.078 E-mail: ready@metSERVICE.com
PAPUA NEW GUINEA	MALAI, Benjamin N. PN National Weather Service P.O. Box 1240 BOROKO, N.C.D. Papua New Guinea	Tel.: 675.325.2788 Fax: 675.325.5544 E-mail: binn_malai@hotmail.com
USA	DIAMOND, Howard J. NOAA/National Climatic Data Center 1100 Wayne Avenue, Suite 1202 Silver Spring MD 20919-5642 United States of America	Tel.: 1.301.427.2475 Fax: 1.301.427.0033 E-mail: howard.diamond@noaa.gov
USA	KNAPP, Kenneth R. NOAA/National Climatic Data Center 1100 Wayne Avenue, Suite 1202 Silver Spring MD 20919-5642 United States of America	Tel.: Fax: E-mail: ken.knapp@noaa.gov
USA	BEVEN, Jack National Hurricane Center Tropical Prediction Center NOAA – NWS 11691 SW 17 th Street MIAMI, Florida 33165-2149 United States of America	Tel.: 1.305.229.4433 Fax: E-mail: john.l.beven@noaa.gov
USA	HAWKINS, Jeffrey Naval Research Laboratory Code 7300, Bldg 1009 STENNIS SPACE CENTER, MS 39529-5004 United States of America	Tel.: 1.228.688.4528 Fax: 1.228.688.4149 E-mail: jeff.hawkins@nrlmry.navy.mil

Appendix A: List of Participants

<p>USA</p>	<p>OLANDER, Timothy University of Wisconsin- Madison/CIMSS 1225 West Dayton Street MADISON, WI 53719 United States of America</p>	<p>Tel.: 1.608.265.8005 Fax: 1.608.262.5974 E-mail: timo@ssec.wisc.edu</p>
<p>USA</p>	<p>TANABE, Raymond Operations WFO, RSMC Honolulu NOAA – NWS 2525 Correa Road HONOLULU, HI 96822-2219 United States of America</p>	<p>Tel.: 1.808.973.5273 Fax: E-mail: raymond.tanabe@noaa.gov</p>
<p>USA</p>	<p>VELDEN, Chris University of Wisconsin CIMSS 1225 West Dayton Street MADISON, WI 53719 United States of America</p>	<p>Tel.: 1.608.262.9168 Fax: 1.608.262.5974 E-mail: chrisv@ssec.wisc.edu</p>
<p>USA</p>	<p>HERNDON, Derrick University of Wisconsin CIMSS 1225 W. Dayton St. MADISON, WI 53704 United States of America</p>	<p>Tel.: Fax: 1.608.262.5974 E-mail: dherndon@ssec.wisc.edu</p>
<p>USA</p>	<p>WIMMERS, Anthony University of Wisconsin CIMSS 1225 W. Dayton St. MADISON, WI 53704 United States of America</p>	<p>Tel.: 1.403.474.6385 Fax: 1.608.262.5974 E-mail: wimmers@ssec.wisc.edu</p>
<p>USA</p>	<p>FUKADA, Edward Mitsugi Technical Adviser U. S. Joint Typhoon Warning Center 425 Luapele Road Pearl Harbor, Hawaii 96860, United States of America</p>	<p>Tel.: 1.808.474.5305 Fax: 1.808.471.4581 E-mail: edward.fukada@navy.mil</p>
<p>USA</p>	<p>KIENZLE, Richard Technical Sergeant U. S. Joint Typhoon Warning Center 425 Luapele Road</p>	<p>Tel.: 1.808.474.3956 Fax: E-mail: Richard.kienzle@navy.mil</p>

Appendix A: List of Participants

	Pearl Harbor, Hawaii 96860, United States of America	
USA	WROE, Derek RSMC Honolulu NOAA – NWS 2525 Correa Road HONOLULU, HI 96822-2219 United States of America	Tel.: 1.808.973.5270 Fax: E-mail: derek.wroe@noaa.gov
USA	LANDER, Mark A. University of Guam UOG/WERI UOG Station Mangilao, Guam United States of America	Tel.: 1.671.735.2695 Fax: 1.671.734.8890 E-mail: mlander@uog9.uog.edu

**INTERNATIONAL WORKSHOP ON
SATELLITE ANALYSIS OF TROPICAL CYCLONES**

HONOLULU, HAWAII, USA
(13 - 16 APRIL 2011)

Programme

Wednesday 13 April 2011 (p.m.)

- 14:00 - 14:30 Opening
- Welcome (*WMO, Kuroiwa; Co-Chairs, Burton and Velden*)
 - Introductions (*All*)
 - Workshop Motivations and Objectives (*Velden*)
- 14:30 - 14:45 Operational Considerations (*Burton*)
- 14:45 - 15:00 Tie-in with IBTrACS Efforts (*Knapp*)
- 15:00 - 15:20 (*Break*)
- 15:20 - 17:30 Satellite TC Analysis in Operations (*by all respective RSMC, TCWC, National Satellite Centers ~20 mins each*)

Thursday 14 April 2011 (a.m. & p.m.)

- 09:00 - 10:30 Satellite TC Analysis in Operations (*cont'd*)
- 10:30 - 10:50 (*Break*)
- 10:50 - 11:50 Satellite TC Analysis in Operations (*cont'd*)
- 11:50 - 12:30 Plenary Discussion (*All*)
- - Summarize satellite analysis and Best Track procedures
 - - Identify local "departures"
- (*Lunch*)
- 14:00 - 15:30 Dvorak Exercise (*All, after Burton instructions*)
- 15:30 - 15:50 (*Break*)
- 15:50 - 17:00 Dvorak Exercise (*cont.*)

Appendix B: Workshop Agenda

Friday 15 April 2011 (a.m. & p.m.)

- 09:00 - 10:30 Plenary Discussion on Dvorak Exercise (Burton/All)
- 10:30 - 10:50 *(Break)*
- 10:50 - 12:20 Training on Objective Satellite-Based TC Analysis Methods (~30 mins each)
- ARCHER (Wimmers/Velden)
 - ADT (Olander/Velden/Turk)
 - AMSU (Herndon/Velden)
- (Lunch)*
- 14:00 - 15:30 Training on Objective Satellite-Based TC Analysis Methods (cont.)
- SATCON (Herndon/Velden)
 - CIRA sfc analysis and KCZ P>W (Burton)
 - PMW (Hawkins)
- 15:30 - 15:50 *(Break)*
- 15:50 - 17:00 Plenary Discussion on how obj. aids may have aided the Dvorak cases (All)

Saturday 16 April 2011 (a.m.)

- 09:00 - 10:30 Summary and final plenary discussion of issues *(Velden/Burton/All)*
- 10:30 - 10:50 *(Break)*
- 10:50 - 11:20 Next Steps (Kuroiwa)
- 11:20 - 12:00 Wrap Up *(Burton/Velden)*

OPERATIONAL PROCEDURES OF TC SATELLITE ANALYSIS AT RSMC LA REUNION

1 SOME MILESTONES ...

- 11 January 1848 : date of the first cyclone-related data in La Réunion's Centre database.
- January 1960 : beginning of "naming era" (first named system TC ALEX). Shift in the database from daily data (only one TC location provided per day at 06Z) to 6hrly data (with addition of the storm type).
- 1967 : real beginning of "satellite era". But first night-time images probably acquired only from cyclone season 1972-1973 (with NOAA 2) but with lot of trouble to navigate the images prior to 1975 (or 1976 ?).
- End of 1968 : Starting using the works from the NESG (U.S. National Environmental Satellite Center), with first attempts of categorizing storms by "intensities" assessed from satellite patterns (derived from the Vincent J. Oliver Classification, which was thereafter used until 1981).
- Mid-1981: Dvorak Technique definitively adopted. But had already been used as the main TC analysis technique during cyclone seasons 1977-1978 and 1978-1979.
- September 1985 :
 - Dvorak intensities and related pressure-wind relationships modified : application of a 0.8 conversion factor to derive Maximum 10-min average winds from Maximum sustained winds.
 - Area of Responsibility extended from 80°E to 90°E : quite a significant increase in a real coverage of the domain and, as a direct result, of the volume of best-track data (but with no upgrade of the satellite coverage, remaining very insufficient to monitor this new eastern portion of the AoR . . . ⇒ lots of uncertain data for this part of the basin –especially east of 80E).
- November 1990 : beginning of "digital imagery era", with the implementation of an HRPT station for the NOAA satellites reception.
- December 1992 : beginning of scatterometer era. First scatterometer data received from ERS 1 (followed by ERS2 and then QuikScat –since season 1999-2000 –and Ascats since July 2007).
- 1st July 1993 :
 - Meteo-France at La Réunion officially designated as the WMO RSMC/Tropical Cyclones for the South-West Indian Ocean. Marginal impact on best-tracks since the Center has already started operating like an RSMC since 1988 (when it was recognized as a Regional Tropical Cyclones Advisory Centre).
 - Some parameters added in the database : RMW (Radius of Maximum Wind), DOCI (Diameter of Outermost Closed Isobar), 30 kt wind radii.
- December 1995 : PDUS station acquired.
- May 1998 :

Appendix C: Satellite Analysis Procedures in Operational Centers

- Beginning of "geostationary era", with the "permanent" coverage of the basin (following the displacement of Meteosat 5 to 63°E for the INDOEX Experiment, replaced by Meteosat 7 by the end of 2006 at 67°E).
- Major increase in spatial (best-track data extending thereafter more eastward –99.9E being the eastern limit –and southward) and temporal sampling (1/2 hourly imagery) of the storms.
- September 1999 –Pressure-Wind Relationship modified :

Application of a 0.88 conversion factor to derive Maximum 10-min average winds from Maximum sustained winds. Gust factor also modified. Main accruing changes :
 - shift towards stronger intensities for the same Dvorak intensity (CI 4.5 now associated with hurricane force winds)
 - for the same maximum winds MSLP now lowered
 - standardization of procedures with other southern hemisphere Centers
- 1999 : beginning of "Internet era" at the RSMC. Access to specialized websites and to their near real-time data. A major revolution in TC monitoring and in our operational practices. Access to microwave data and to more scatterometer data.
- 2002 : cyclone seasons now considered to start on 1st July (instead of 1st August).
- September 2003 :
 - Application of the new WMO best-track format.
 - Addition of new parameters in the database : peak gust, 50 kt wind radii, plus quality codes.
 - RSMC's Area of Responsibility enlarged from the Equator to 40°S (instead of 5°S to 30°S). Some impact on operations but no real impact on best-tracks (since the systems were already best-tracked for their entire life-cycle).
- 2005 : acquisition of MSG imagery. Increased frequency of imagery on the western part of the basin (every 15 min) with new channels and increased resolution (High Resolution Visible in particular).

2 WHAT ARE LOCAL VARIATIONS TO DVORAK (1984) ROUTINELY USED IN ANALYSIS AT YOUR CENTER?

2.1 Local specificities depending on Pattern

2.1.1 Curved Band pattern

- A band with existing small breaks must be considered as continuous band axis

2.1.2 Shear pattern

- We mostly use this pattern for mature systems starting to undergo weakening through windshear. Shear pattern analysis is generally not relevant for early stages and final

stages of life-cycles when diurnal fluctuations linked to puffs or flare ups of convective activity induce rapid variations of separation distance between the LLCC and the convection. In such situations we generally avoid using “instantaneous” T-numbers and just consider evolutions on a larger time-frame to avoid being “cheated” by more or less short-lived non significant evolutions.

- Not only the Dvorak Technique is not suitable for extratropical system, but much caution is required for systems about to transition into extratropical systems although still looking quite tropical (generally associated to an incipient shearing pattern). Experience has shown that you must stop analyzing the storm with Dvorak (shear pattern) enough early to avoid being trapped and ending under-estimating the real intensity.

2.1.3 Eye pattern

- Enhanced Infrared technique is quite recently used (one decade) at La Reunion but is now considered being the more relevant. However EIR analyses remain occasionally adjusted/tempered by the VIS technique.
- EIR technique is used with a local coloured and more readable Palette.
- One of the possible issues come from the current improved satellite resolution compared to what it was in 1984. We do not consider small departures that may be caused by a few isolated pixels (either warmer - in the convective ring region - or colder - in the eye region). We try to imagine what the image would look with a coarser resolution (very empirical hence). For instance isolated pixels are not considered to constitute a significant discontinuity when measuring the width of the coldest ring that completely encircles the eye (when determining the EIR Eye-number). The same for assessing the Eye adjustment factor for the eye region.
- However for small eye or pinhole eyes affected by the viewing angle of the geostationary satellite normally used, when a good polar orbiting image is available with a good FOV (showing hence a warmer eye) we tend to consider the latter as more suitable for the intensity analysis (if enough warmest pixels present to assume that they would be seen by a geostationary located at the nadir of the TC even with lower resolution).

2.1.4 CDO pattern

- During night-time, we use Infrared imagery with dynamical grey-shade to filter Cirrus and build a CDO-like picture. This one is analyzed as first guess like a CDO Vis pattern.

2.1.5 Embedded Center pattern

- EIR is generally not used because it overestimates intensity.
- It seems to be only relevant for systems with the eye having just recently disappeared.

2.2 T-Number

The T-number is an average over different periods in relationship with system size (not obvious to qualify). We assume the lower limit extension for a normal size system as 200 km gale radius discarding the parasitic effect of induced environmental influences like motion speed, gradient effect..)

- “normal size” or “broad size” systems T-numbers have been averaged over 6 hours consecutive imagery.

- “small size” systems have been averaged over 3 hours consecutive imagery. Very small size systems (midgets systems) are also an issue, since the Dvorak Technique probably generally underestimates the real intensity.

2.3 Local specificities depending on stages

2.3.1 Weakening stages

- “normal size” or “broad size” systems have been consider to have a 12 hours period of inertia before weakening
- “small size” systems have been consider to have a 6 hours period of inertia before weakening

2.3.2 Deepening stages

- Dvorak constraints are unhesitatingly broken for “small size” systems undergoing very rapid intensification.

2.3.3 Overland analysis

- When a system has made landfall, we rapidly stop Dvorak analysis.

2.3.4 Extratropical transition

- Beware with Extratropical transition phases! Local analysts try to be careful aborting Dvorak Technique soon enough. It underestimates intensity.

3 HOW UNIFORMLY IS DVORAK APPLIED WITHIN YOUR OPERATIONAL CENTER (ARE THERE SYSTEMATIC VARIATIONS BETWEEN ANALYSTS)?

- Dvorak is (hoped to be) quite uniformly applied, but Dvorak analysis remains intrinsically subjective for a part of it and is sensitive to the own personality of each analyst (that may be more or less conservative). We don't however think that a systematic variation between analysts should exist.
- In operational time, some psychological thresholds (Tropical Storm, Hurricane) or political ones (local warning system, naming procedures) may occasionally affect analysis (especially so when naming is involved –at moderate tropical storm stage –since RSMC La Réunion has not the naming responsibility), but not for post-analysis and “best-tracking”.

4 HOW HAVE PROCEDURES CHANGED OVER TIME?

After being experimented during two cyclone seasons (1977-1978 and 1978-1979), the Vernon Dvorak Technique was definitively adopted at La Réunion's Centre from cyclone season 1981-1982 onwards.

- Prior to that (and during cyclone seasons 1979-1980 and 1980-1981), the Vincent J. Oliver Classification (“Tropical Storm classification system”, National Environmental Satellite Center document, June 1968) was used (based on satellite cloud patterns defined as A, B, C and X phases). A related monogram provided estimates of the maximum winds for the different X phases (X1 to X4) depending on the average size of the central cloud cover. But prior to 1977- 1978 it can be said that MSLP and Maximum Winds were very coarsely estimated.

- The application of the Dvorak Technique has evolved with time. In particular, the BD enhancement arrived lately (coming with the digital imagery in the early 1990's). One main consequence is that the Enhanced Infrared (EIR) analysis Technique took time to be integrated and that the Dvorak Visible Technique was privileged almost till the end of the 1990s.
- The Pressure-Winds Relationships applied have also evolved with time (Tab. 1 - Sec. 8). In particular application of environmental pressure and TC size adjustments to the MSLP are relatively recent.

5 DOES THE FINAL INTENSITY ESTIMATE ALWAYS MATCH THE CI?

Until quite recently we avoided having discrepancies between both (which was justified by the fact that intensities were almost exclusively based on the Dvorak satellite intensity analysis). We now allow ourselves to have “inconsistencies” between Ci and Maximum Winds (whose estimate takes into account other available data like Microwave imagery, ADT, Satcon, Scatterometer data, Observations). So, Dvorak intensity is the first guess but the final intensity is now a blended analysis taking into account all available elements. For small size systems (midgets) the intensity may be biased upward (Dvorak being assumed to underestimate the true intensity).

6 HOW HAVE TECHNOLOGICAL ADVANCEMENTS INFLUENCED DVORAK ANALYSIS? (ACCESS TO SATELLITE IMAGERY, USE OF MCIDAS OR SIM-ILAR)

Plenty satellite pictures were not available at La Reunion's Tropical Cyclone Centre in the past (DMSP, NOAA orbits outside of our scope of acquisition) or have been more or less poorly exploited (Dvorak not used or inappropriately used ... no digital but manually gridded hardcopy printouts pictures).

6.1 Access to satellite imagery

- After the real beginning of the “satellite era” (in 1967), there was a lot of trouble to navigate the images prior to 1975.
- The beginning of “geostationary era” with the “permanent” coverage of the basin from May 1998 resulted in a major increase in spatial and temporal sampling.
- A lot of new products have been available since the onset of “Internet era” at the RSMC (1999). Analysts were able to access to specialized websites and to their near real-time data (microwave and scatterometer).
- The last major satellite evolution was the acquisition of MSG imagery in 2005 (even though it only covers the western part of our basin –mainly the Mozambique Channel). Frequency of imagery increased (every 15 min) with new channels (night-time coloured composite for example) and resolution also increased (High Resolution Visible made available in particular).

6.2 Tools and software technological advancements

- The beginning of “digital imagery era” at La Reunion's RSMC (in 1990, with the implementation of an HRPT station for the NOAA satellites reception) was a major evolution with accruing improved quality of Dvorak analysis. It enabled analysts to zoom in or out on pictures, to use new coloured or enhanced palette, to adjust dynamically the pictures.
- The Meteo-France workstation Synergie was implemented at the RSMC in 1996 (after

the PDUS station acquired). It represented a new operational way for analysis which was therefore able to superimpose and animate “classical” data, like satellite imagery, observations, available scatterometry

- Access to specialized websites in 1999 was a major revolution in TC monitoring and in our operational practices
- The more recent (2009) technological advancement was the convergence of classical satellite, internet and trajectory products on the same in-house software Synergie-Cyclone. Analysts are now able to superimpose all the products, to create adapted transparency between the layers, to “mouse-plot” directly the analysis related to a picture.

7 WHAT ANCILLARY DATA DO YOU CONSIDER BEFORE YOU PRODUCE THE FINAL SATELLITE INTENSITY ESTIMATE (I.E. MICROWAVE, ADT, ETC)?

Dvorak’s weight in the final intensity estimate has been significantly reduced during the last decade as ancillary data has become more and more available.

7.1 Scatterometry

Scatterometry is not usable to determinate high intensities but is commonly used in the range of 30kt to 40kt (as a “minimum maximorum” proxy). For strongest storms, scatterometry is only used for wind radii assessments (extension of gales).

7.2 Microwave imagery

Microwave imagery advent has been a revolution in the TC analysis business. It is often now a major and decisive element in the analysis process. Now being used as a primary tool to assess the degree of organization of the inner core of the system. Especially powerful for the following patterns or stages:

- CDO pattern : the microwave can better apprehend the internal evolutions (building eye starting to show much earlier than on IR or even Vis) thus enabling to adjust the Dvorak intensity (and avoid the classical “plateau” effect with the single use of the Dvorak analysis of classical imagery).
- Shear pattern : by improving the LLCC location but also by measuring the distance between LLCC and the border of the deep convective activity, which can be not so obvious on classical imagery (especially at night with only IR).
- Curved Band Pattern : by facilitating the assessment of the starting and ending points of the curved band axis.
- Early stages : by improving the LLCC location or better highlighting significant structures or features (especially the 37 or 36 GHz channel that depict very nicely the LLCC and organization in the lower levels).

7.3 AMSU, ADT

This kind of computed data are mainly used for intense TCs (does not work very well for weak systems especially AMSU–A derived intensities). Are used cautiously on a case by case basis (taking into account all elements that may affect the quality of these data : for instance the field of view or the eye size/RMW for the AMSU–A data).

8 WHAT CI-PRESSURE-WIND RELATIONS ARE IN USE AT YOUR OPERATIONAL CENTER AND HAVE THESE CHANGED OVER TIME?

2010-2011 TC season is the first season with MSLP computed thanks to Wind-Pressure Relationship Courtney & Knaff. See below a history of Dvorak intensities and associated pressure-winds relationships at La Réunion's Centre.

CI Dvorak	10 min Max Wind (1 min) ⁰	Peak gust	MSLP (hPa)	10 min Max Wind (1 min) ⁰	Peak gust	MSLP (hPa)	10 min Max Wind (1 min)	Peak gust	MSLP (hPa)
1.0	20 (25)	31	1010	20 (25)	30		22 (25)	31	
1.5	20 (25)	31	1007	20 (25)	30		22 (25)	31	
2.0	24 (30)	37	1004	24 (30)	36	1000	26 (30)	37	1000
2.5	28 (35)	43	1000	28 (35)	42	997	31 (35)	43	997
3.0	32 (40)	50	995	36 (45)	54	991	40 (45)	56	991
3.5	40 (50)	62	990	44 (55)	66	984	48 (55)	68	984
4.0	48 (60)	75	985	52 (65)	78	976	57 (65)	80	976
4.5	58 (72)	90	976	62 (77)	93	966	68 (77)	96	966
5.0	68 (85)	105	967	72 (90)	108	954	79 (90)	112	954
5.5	78 (97)	121	957	82 (102)	123	941	90 (102)	127	941
6.0	88 (110)	137	945	92 (115)	138	927	101 (115)	143	927
6.5	98 (122)	152	931	102 (127)	153	914	112 (127)	158	914
7.0	108 (135)	168	917	112 (140)	168	898	123 (140)	174	898
7.5	120 (150)	187	903	124 (155)	186	879	136 (155)	192	879
8.0	136 (170)	209	888	136 (170)	204	858	150 (170)	211	858
Origin	Conversion factor of 0.8 on MSW ¹	gust factor of 1.55 or 1.25	Average of ATL and NWP scales ²	Conversion factor of 0.8 on MSW	gust factor of 1.5	NWP scale (Shewchuk and Weir)	Conversion factor of 0.8 on MSW	gust factor of 1.41	Not Modified (NWP scale)
Period	From 1977-78 to 1984-85 ³			From 1985-86 to 1998-99			From 2000-01 to 2009-10		

Table 1: Dvorak intensities and associated pressure-winds relationships at La Réunion's Centre.

- 0 The Maximum Sustained 1-min Wind speed (MSW) values did not correspond to the figures found in the Global Guide to TC forecasting (1993) for CI values between 3.0 and 7.5 (with values being 5 kt less). This "anomaly" was apparently rectified in 1985.
- 1 This conversion factor was only applied during the cyclone season 1984-1985. While it is clearly mentioned in that season's report that a conversion indeed applied to derive the 10-min average winds from the 1-min sustained winds, this is not explicit in the reports from the previous seasons, where it is only said that : "the original wind scale (MSW) was retained"; whereas for the MSLP : "an average between the ATL and NWP values was chosen". A thorough reading of the reports brings however strong evidence that prior to 1984-1985 there was no distinction being made between 10-min or 1-min average winds (the Dvorak-MSW correspondence scale hence being used raw). In fact the first mention of 10-min average winds can be traced back to 1982 following the 8th session of the AR I meeting where the new version of the Operational Plan proposed by the South-West Indian Ocean Tropical Cyclone Committee was adopted (concomitantly with a new more detailed classification of the tropical systems in the basin).
- 2 Did not correspond however to the average values of MSLP derived from the ATL and NWP figures indicated in the Global Guide to TC forecasting (1993) ?
- 3 Except for the cyclone seasons 1979-1980 and 1980-1981, for which the Dvorak Technique was temporarily set by to come back to the Vincent J. Oliver Classification.

9 WHAT CRITERIA ARE USED TO DECIDE WHICH SYSTEMS TO ENTER INTO YOUR BEST TRACK RECORDS?

9.1 The internal policy

The internal policy is since a decade to keep in the final best-track database only the significant storms, i.e. the one which have been analysed as tropical depression (10-min average Max Winds of near-gale force) for at least 24 hours. This was not the case in the past. In the database we can find many systems –even named –that were weak systems, some of them not even now considered as tropical depressions (even in the satellite era –in the 1960s and 1970s mostly). We make our own BT for the systems which cross the eastern border of our AOR (90° East), even the Australian or the Indonesian part of the track. Significant Subtropical TCs are also integrated in the final best-track database.

9.2 Best-track elaboration process

The "final" best-track elaboration can be described as a three steps process :

1. An "analysis database" is constructed from real time to near-real time satellite (or radar) data from all origins acquired : it contains TC analyses at random hours with one point every 4 (to 6) hours in average. Short-term track oscillations (like trochoidal motion) are generally smoothed.
2. This "analysis database" is subject to corrections made in near-real time (generally within 24 hours) in order to generate an "operational best-track" with 6 hourly positions generated by interpolating the data from the "analysis database" : at this stage most corrections concern LLCC locations.
3. Additional post-storm re-analysis and corrections are made within 1 to 6 months after the end of the storm's life-cycle : little impact on LLCC locations, but greater impact on intensities and even more for other parameters (wind radii, RMW, etc . . .).

9.3 Distribution of main parameters within La Réunion's cyclone database

Periods	Jan 1848-1960	Nov 1960-1977	Nov 1977-1993	Nov 1993-2003	Since Nov 2003
Number of systems	738	185			
TC name	Numerical	Alphanumerical (Naming era)			
Date	X	X	X	X	X
LLCC Lat/Lon	X 06Z daily locations (5203)	X 6hrly (1504)	X 6hrly ()	X 6hrly ()	X 6hrly ()
Storm Type	No	X	X	X	X
Dvorak Intensities	No	No	¹	X	X
Max Wind	No	No	X ²	X ⁴	X
MSLP	No	No	X ³	X ⁴	X
LLCC Confidence	No	No	No	X	X
RMW	No	No	No	X	X
DOCI	No	No	No	X	X
30 kt Wind Radii	No	No	No	X	X
50 kt Wind Radii	No	No	No	No	X
Peak gust	No	No	No	No	X

Table 2: Distribution of main parameters within La Réunion cyclone database.

- ¹ check comments of Tab. 1 T numbers lacking between 1990 and 1992 (?).
- ² pressure-winds relationships not homogeneous within this period (see related details in comments of Tab. 1).
- ³ See Tab. 1 and related comments (² in particular).
- ⁴ pressure-winds relationships not homogeneous (modified in Sept 1999).

OPERATIONAL USE OF THE DVORAK TECHNIQUE AND ASSOCIATED ISSUES AT THE NATIONAL HURRICANE CENTER, MIAMI, FLORIDA, USA

1. The Tropical Analysis and Forecast Branch (TAFB) of the National Hurricane Center (NHC) performs manual subjective Dvorak location and intensity estimates. The TAFB also performs similar estimates for subtropical cyclones using the Hebert-Poteat subtropical cyclone technique.
2. It is the NHC philosophy that these estimates are supposed to be as independent of other data sources as possible (which is not 100% possible).
3. Full Dvorak analyses are made every six hours at the synoptic times, with locations provided at the intermediate synoptic times. Full Dvorak analyses can be made at non-synoptic times if necessary.
4. The TAFB uses the 1984 version of the Dvorak Technique. No changes have been made to the basic calibration, and the winds and pressures reported to the HSU use the 1984 tables. There are also no departures from the technique flow charts.
5. Departures from Dvorak (1984) in TAFB operations:
 - a. Cloud systems centers that do not meet the convective criteria can be tracked by providing a location and an intensity estimate of “too weak to classify”.
 - b. When measuring infrared eye patterns in step 2C, occasionally a BD enhancement color completely surrounds the eye that is too narrow to use for the eye number. In these cases, the color shade is not used to determine the eye **number**, but is used to determine the eye **adjustment**. The following image is an example from Atlantic Hurricane Jeanne in September 2004.

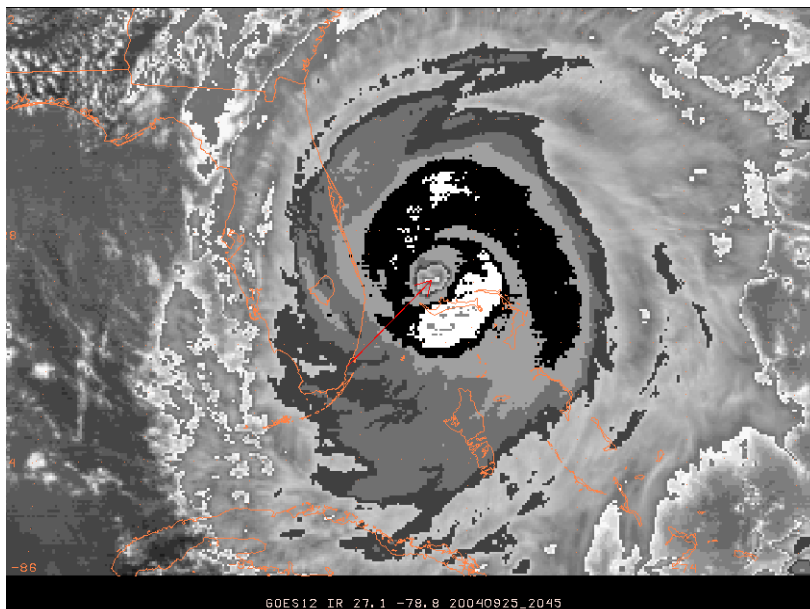

- c. On page 36 of Dvorak (1984) there is a rule concerning the eye adjustment for large or elongated eyes in infrared imagery as part of step 2C. The TAFB does not use this rule.
- d. For the visible eye patterns in step 2C and the visible CDO pattern in step 2D, the TAFB interpolates between the distances/sizes given in the tables to produce Central Feature numbers at 0.5 T-number resolution.

Appendix C: Satellite Analysis Procedures in Operational Centers

- e. For Pattern T-Numbers in step 6, the TAFB does not strictly follow the rule that the Pattern T-Number must be within one column (0.5 T-Numbers) of the Model Expected T-Number.
- f. The TAFB uses a modified set of the Dvorak (1984) constraints on the allowed Final T-Number changes in steps 7 and 8 based on Lushine (1977). This deals with when the analyst can allow a looser constraint on changes in the Final T-number. The differences are in the following table.

Original FT Constraints for storms with $T \geq 4.0$ (Dvorak):	Modified FT Constraints now in use for developing storms above T1.5 (24 hr or more after the initial T1) (Lushine 1977):
	1.0 T-numbers over 6 hr
	1.5 T-numbers over 12 hr
	2.0 T-numbers over 18 hr
	2.5 T-numbers over 24 hr

- g. For the forecast intensity in step 10, the TAFB uses a combination of Dvorak (1984) and rules from the version of the technique published in 1995.
- h. For systems that spend a significant amount of time over land and then re-emerge over water, the TAFB re-starts Dvorak analyses using the observed Data T-Number and Pattern T-Number.

6. The Hurricane Specialist Unit (HSU) of the NHC creates the tropical cyclone forecasts. This unit uses the Dvorak estimates from TAFB, as well as one provided by the Satellite Analysis Branch, in its operations. It is the responsibility of the HSU to integrate the Dvorak analyses with other data sources (when available). Even when Dvorak estimates are the only data source, **the HSU forecasters are free to employ the Dvorak analyses in whatever way they feel is appropriate.** This applies to both real-time forecasting and post-analysis.

7. The Advanced Dvorak Technique (ADT) developed by the Cooperative Institute for Meteorological Satellite Studies at the University of Wisconsin is not yet considered operational by the NHC. The ADT data are used as a supplement to the manual estimates.

REFERENCES:

Dvorak, V. E., 1984: Tropical cyclone intensity analysis using satellite data. NOAA Tech. Rep. NESDIS 11, National Oceanic and Atmospheric Administration, Washington, DC, 47 pp.

Dvorak, V. E., 1995: Tropical clouds and cloud systems observed in satellite imagery: Tropical cyclones. Workbook Vol. 2., 359 pp. [Available from NOAA/NESDIS, 5200 Auth Rd., Washington, DC, 20333.]

Hebert, P. J., and K. O. Potat, 1975: A satellite classification technique for subtropical cyclones. NOAA Technical Memorandum NWS SR-83, U.S. Dept. of Commerce, National Weather Service, Ft. Worth TX, 25 pp.

Lushine, J.B., 1977: A Relationship Between Weakening of Tropical Cyclone Cloud Patterns and Lessening of Wind Speed. NOAA Tech. Mem. NESS 85, 12 pp.

USE OF DVORAK TECHNIQUE IN RSMC NEW DELHI, INDIA

1. INTRODUCTION

With the launch of Television Infrared Operational Satellite (TIROS) in 1960 by USA, the era of using satellite pictures for weather forecasting has begun. Satellite data have also been used for tropical cyclone location and intensity analysis. It is worth to mention that before the advent of weather satellite cyclones could have formed over north Indian Ocean and got dissipated without the knowledge of the forecaster. To explore the application of satellite products in weather monitoring and forecasting in pre Dvorak era the satellite imagery was used for detection and analysis of tropical cyclones. Earlier satellite provided only one picture a day of a tropical cyclone. Experiences gained in the late 60's using good quality of satellite pictures had observed tropical cyclones and their life cycle. Initial method for the intensity was based on the appearance of the storm's eye, its banding and the intensity and size of cloud pattern. These methods were useful for approximating the intensity of tropical cyclones in most cases, but they had serious shortcoming when the cloud pattern of tropical cyclone was either unclear or when it was undergoing extreme short-period change.

The technique for estimating position and intensity of tropical cyclones has been formulated by Dvorak (1975) observing satellite imageries which gained widespread acceptance. Subsequently there has been number of changes with respect to technology, operational procedure, access to satellite products etc. All the above discussed in the following sections.

2. DEVELOPMENT OF SATELLITE TECHNOLOGY

Satellite based techniques for the estimation of the intensity of tropical cyclones and monitoring their development underwent a rapid evaluation in step with advances in satellite technologies. With later versions of the TIROS satellites, night-time observations with infrared sensors became possible. Subsequently, geostationary meteorological satellites, like GOES, GMS and Meteosat placed tropical cyclones under round-the-clock surveillance. Indian meteorologists have been privileged in this respect by having a succession of six geostationary satellites of the INSAT series, with meteorological payloads, located over the Indian Ocean since 1982. India's own INSAT-2E satellite launched in 1999 carried an advanced payload operating in three channels – visible, infrared and water vapour. Besides this, it carried a CCD camera with one km. resolution and with three channels visible, near infrared and short wave infrared (Koteswaram, 1971; Kalsi, 2002).

A geostationary meteorological satellite (METSAT) system devoted totally to meteorology has been launched in 2002, it has been renamed as Kalpana-1 and is currently the operational satellite system being used by IMD. INSAT-3A satellite has been launched in April 2003 which carries identical payloads as in INSAT-2E.

The chronological details of the satellite used in IMD are shown in Table-I. The characteristics of the satellites like resolution etc are shown in Table-2

Table-1

SATELLITE	LAUNCH
INSAT -2A	July 1992
INSAT -1D	June 1990
INSAT -2E	May 1999
KALPANA -1	September 2002
INSAT -3A	May 2003

Table-2

INSAT -1D	INSAT -2A/2B	INSAT -2E/ INSAT – 3A
-----------	--------------	-----------------------

Appendix C: Satellite Analysis Procedures in Operational Centers

Parameters	Visible	IR	Visible	IR	Visible	IR	WV	CCD
Spatial Resolution	2.75	11	2.0	8.0	2.0	8.0	8.0	1

3. ANALYSIS PROCEDURE

Dvorak himself modified his technique for the analysis and forecasting of tropical cyclones based on satellite imageries since his first technique introduced in 1973 when he used only visible pictures. In 1975 he included IR pictures also. Later on he proposed in 1984 the use of both visible and IR pictures also enhanced infrared (EIR) imageries. The digital IR has also been added to the technique later. The uses of EIR and digital IR have made the technique more simple and objective than the case when only visible data used. IMD uses all the above techniques as and when available.

Dvorak techniques have been applied in IMD since its inception. Also there has been post analysis of cyclones from 1967 based on Dvorak technique (Mishra and Raj, 1975). The first imagery analysis with T- number is shown in Fig. 1.

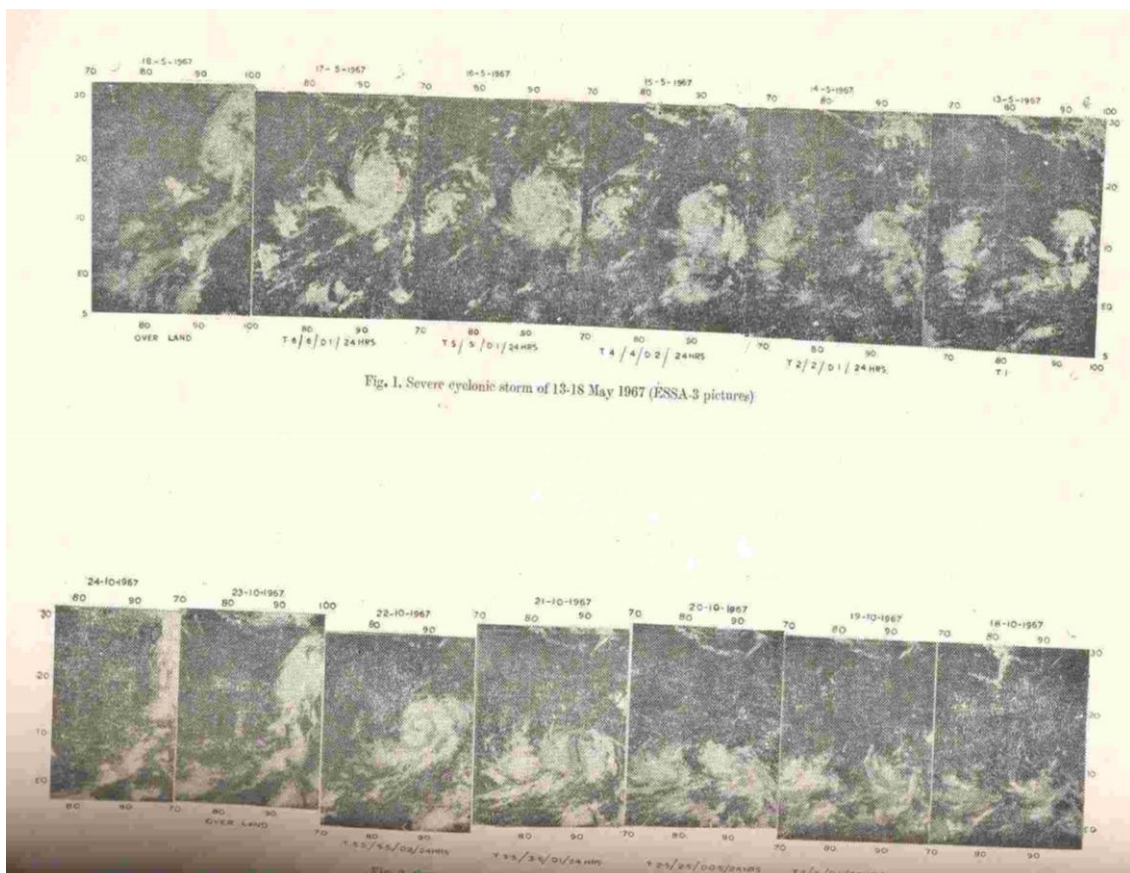

Fig. 1

4. CURRENT PROCEDURE OF INTENSITY ANALYSIS BASED ON DVORAK TECHNIQUE

Dvorak technique has been the mainstay of the operational analysis for over three decades and a half. It has stood the test of time and has provided operational support in all the tropical

Appendix C: Satellite Analysis Procedures in Operational Centers

cyclone warning offices over the world. Though it has been based mainly on the visual examination of the satellite imagery, it continues to be one single most important technique that is relevant even in today's digital age. The classification used in India is as follows:

System	CI No	Wind speed (Kt)
Well Marked Low	1	<17
Depression	1.5	17 to 27
Deep Depression	2	28 to 33
Cyclonic Storm	3	34 to 47
Severe Cyclonic Storm	3.5	48 to 63
Very Severe Cyclonic Storm	4 to 6	64 to 119
Super Cyclonic Storm	6.5 to 8	>120

Visible and IR imageries from Kalpana-1 are being used for estimation of centre and intensity of tropical cyclones. Now a days Microwave and other imageries are also available from SSMI, SSMIS, TMI, AMSRE, WINDSAT, AMSUB satellites and can be accessed through cyclone module in SYNERGIE system installed at National Weather Forecasting Centre (NWFC) of IMD in 2009 and has the facility to integrate everything i.e. Synoptic Observations, Satellite observations, NWP and RADAR and hence have proved very successful in centre estimation of weaker tropical systems. Now Satmet Division is also providing radius of maximum wind in four quadrants for eye pattern to the forecasters based on cloud top temperature. Satellite division is analyzing following satellite products for tropical cyclones:

1. INSAT-Kalpana-1 imageries
2. Cloud top temperatures
3. Cloud motion vector in lower, middle and upper troposphere
4. Water vapour derived winds
5. Outgoing long wave radiation (OLR)
6. Quantitative Precipitation estimation (QPE)
7. Meteosat products like, wind shear, shear tendency etc.
8. Scatterometer Winds.
9. Microwave imageries.

The example of various products in connection with cyclone Gonu are shown in Fig. 2.

Appendix C: Satellite Analysis Procedures in Operational Centers

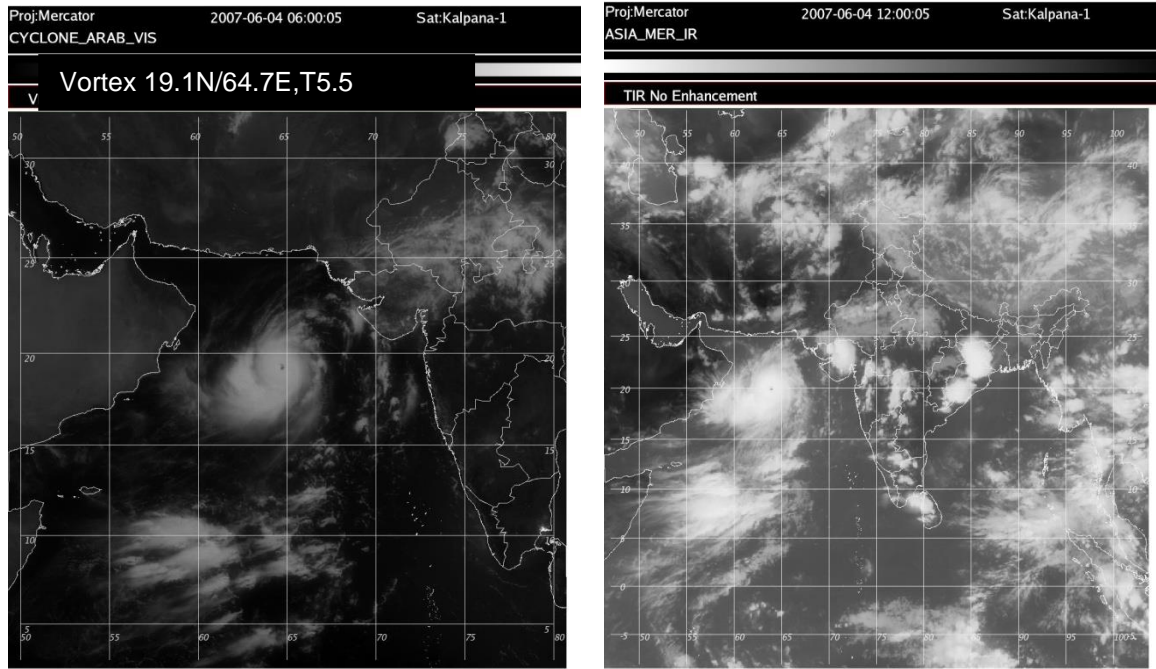

Fig. 2: Kalpana-I visible and infrared imagery for 4th June 2007.

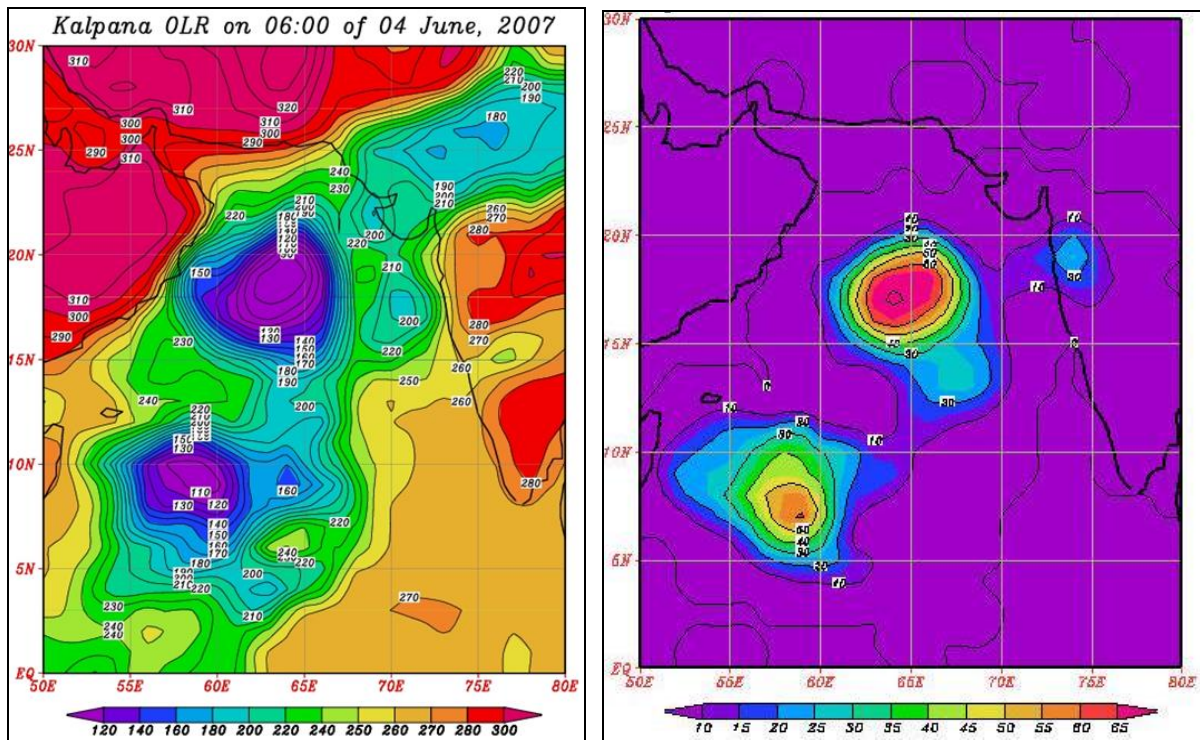

Fig. 3: Kalpana-I derived OLR and QPE for 4th June 2007.

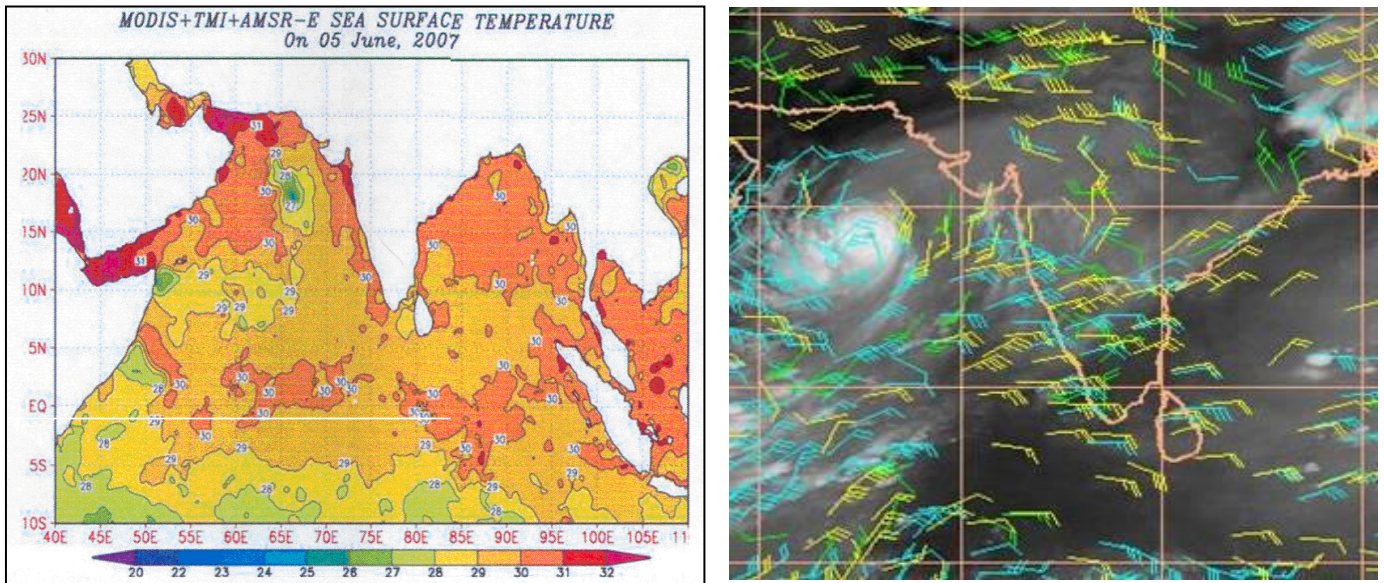

Fig. 4: (a) SST derived from MODIS+TMI+AMSR-E and (b) Meteosat water vapour winds.

5. MAXIMUM SUSTAINED WIND (MSW) AND T-NUMBER

The MSW is estimated from the T number determined by IMD when the system is out of sea. The relationship between T number and MSW used in IMD varies from Atlantic Ocean is shown in Table 3

Table 3

T.No./C.I No.	Wind Speed in Knots (Atlantic)	Wind Speed in Knots (IMD)
T1.0	25	<17
T1.5	25	25
T2.0	30	30
T2.5	35	35
T3.0	45	45
T3.5	55	55
T4.0	65	65
T4.5	77	77
T5.0	90	90
T5.5	102	102
T6.0	115	115
T6.5	127	127
T7.0	140	140
T7.5	155	155
T8.0	170	170

6. ACCESSIBILITY OF SATELLITE PRODUCTS

Problems and Prospects

There are a few problems faced with the applications of Dvorak Techniques in north Indian Oceans.

- i. Intensity estimation of weaker systems: Dvorak has also expressed his view that intensity and centre estimation is difficult for the systems with T number less than 2.5. In this case microwave imagery and scatterometer data are helpful for centre estimation.

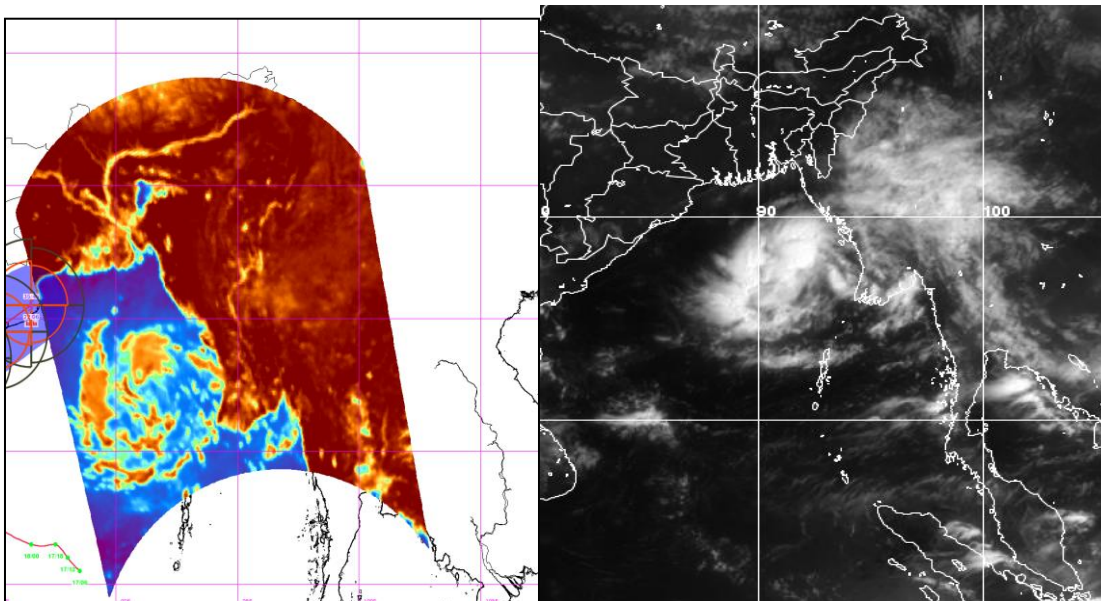
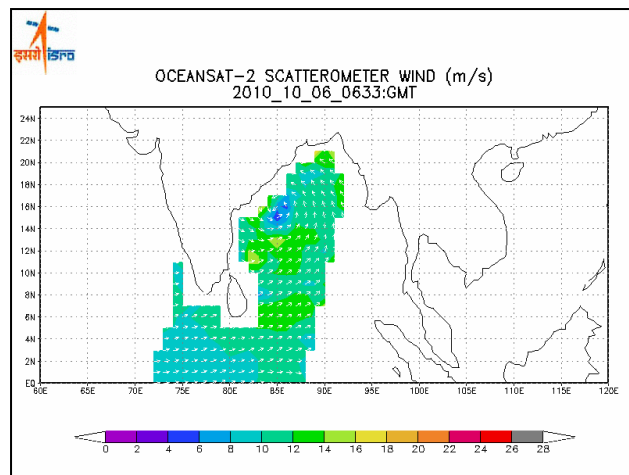

Fig. 4: (a) OCEANSAT-2 scatterometer data fro depression over Bay of Bengal and (b) Microwave (85GHz) and visible imagery for cyclone 'Giri'.

- ii. Intensity of rapidly intensifying systems: In the case of rapidly intensifying system like Giri (20 to 22 October 2010) over Bay of Bengal Dvorak Technique rule are not satisfying.
Rapidly intensifying systems Dvorak technique fails.
Final T no. limits:
 $< T_4$; change of $\frac{1}{2}$ over 6 hours
 $\geq T_4$; change of 1 over 6 hours, 1.5 over 12 hrs,
 2.0 over 18 hrs and 2.5 over 24 hrs.
 Final T no. must equal to $MET \pm 1$.
 Example: Tropical Cyclone "GIRI" from 20 to 22 Oct 2010. Maximum Intensity reached 5.5
- iii. Intensity of highly sheared systems like monsoon depression: For highly sheared systems like monsoon depression, it is observed that most of the time synoptically a system is declared as a depression but clouds feature does not indicate intensity as 1.5.
- iv. Intensity estimation over land surface: Dvorak Technique is not applied for land surface. However, unlike a few countries where Dvorak Technique is also used for land surface, IMD does not apply it over land surface.

Appendix C: Satellite Analysis Procedures in Operational Centers

- v. Intensity estimation varies from person to person. To avoid this, mutual discussion is being held between meteorologists before giving final T number.
- vi. Automated Dvorak Techniques: ADT version 7.2.2 was installed by SAC (ISRO) Ahmedabad at IMD, HQ in October, 2009. It is observed that in general ADT estimates are higher than SATMET estimates and CIMSS ADT result by T1.0 to T1.5 and around T0.5 numbers respectively. In some case it is also seen that in initial stages of development ADT estimates also shows sudden increase in intensity.

ADT results

- vii. Inter agency differences:
 - (a) Some times systems were tracked by India Meteorological Department, but not by SSD NOAA and vice versa.
 - (b) Some times systems were tracked by India Meteorological Department, but not by SSD NOAA and vice versa.
 - (c) Inter Agency Difference in Position and Intensity of the Vortex
Example: GIRI over Bay of Bengal During 20 – 22 Oct, 2010.

Date	Time (UTC)	Position (Lat / Long)	Intensity	SSD-NOAA	JTWC
20-10-2010	0600	16.5/91.5	T1.0		
	0900	17.0/ 91.5	T1.0	T2.0	
	1200	17.5/ 91.5	<u>T1.5</u>		
	1700	17.5/ 91.5	T1.5		
	2100			T2.5	
21-10-2010	0300	17.5/ 91.5	T2.0	T3.0	
	0600	17.5/ 91.5	T2.5	T3.0	
	1100	17.6/ 91.8	T3.0		
	1500		T3.0	T4.0	
	1700	18.0/ 92.2	T3.0		
	2100	18.2/ 92.4	<u>T3.5</u>	T4.5	
22-10-2010	0000	18.5/ 92.6	T3.5		T5.0
	0100	18.5/ 92.6	T4.0		
	0300	18.8/ 92.8	<u>T4.5</u>	T6.0	
	0600	19.0/ 93.0	T5.0		
	0900	19.2/ 93.1	<u>T5.5</u>	T6.5	T6.0
	1200	19.9/ 93.3	T5.5		T7.0
	1400	20.1/93.3	<u>Overland</u>		

Future Aspects:-

1. INSAT-3D Satellite Scheduled to be launched in the 3rd quarter of 2011 payloads. It has a 6-channel Imager almost similar to GOES satellites of USA. It has a 19 –channel Sounder similar to GOES satellites. It has a Data Relay Transponder (DRT) similar to Kalpana-1 and INSAT-3A
2. Megha tropique is expected to be launched in 2011 and shall have the following payloads

Appendix C: Satellite Analysis Procedures in Operational Centers

- a) Microwave Analysis and Detection of Rain and Atmospheric Structures (MADRAS), with five channels of microwave for estimation of atmospheric water parameters in the equatorial belt.
 - b) SAPHIR microwave humidity sounder and radiometer of 6 channels for humidity profile.
 - c) SCARAB-broadband radiation measurement for measurement of Radiation fluxes.
3. Aircraft Observations are likely to be available from Oct, 2011 so that DVORAK technique can be modified for Indian Region.
 4. Till 2009 facility was not available for centre determination by MICROWAVE imagery but from 2010 onwards Navy Nrl site can be access from CYCLONE MODULE installed in SYNERGIE system so microwave intensity can also be found out.

References:-

1. Bhatia R.C. and Singh Devender and Giri, R.K., 2006 "Use of METEOSAT-5 derived winds for operational weather forecasting"., Eighth International winds workshop, Beijing, China, 24-28 April 2006.
2. Dvorak, V.F., 1975: Tropical Cyclone Intensity analysis and forecasting from satellite imagery. *Mon.Wea.Rev.* 103,420-430.
3. Dvorak, V.F., 1984: Tropical Cyclone Intensity analysis and forecasting from satellite data. *NOAA Technical Report, NESDIS 11.*
4. IMD, 2003, "Cyclone manual", published by India Meteorological Department.
5. IMD, 2008, "Cyclone e-Atlas published by India Meteorological Department.
6. Kelkar, R.R., 1997, Satellite based monitoring and prediction of tropical cyclone intensity and movement", *Mausam*, 48, 157-168.
7. Kalsi S R., 2002, "Use of Satellite imagery in Tropical cyclone intensity analysis and forecasting", IMD Met. Mono., No. 1/2002.
8. Koteshwaram, P., 1971, "A decade of satellite meteorology in India", Indian J. of Met. Hydrol. Geophys, V ol. 22, 273-278.
9. Mishra and Raj, 1975, A satellite study of intensities of cyclonic storms in the Bay of Bengal, Indian J. of Met. Hydrol. Geophys, V ol. 26,455-464.
10. Tyagi, A; Biswas, H.R.; Sharma, A.K.; Goyal, S.; Tomar, C.S., 2010; "A technical report on Interpretation and application of satellite imageries /products in weather analysis"; IMD Met. Mono., No. SAT MET 01/2010.
11. WMO,1977, The use of satellite imagery in Tropical Cyclone Analysis, WMO technological note 153,

OPERATIONAL TROPICAL CYCLONE ANALYSIS BY RSMC TOKYO, JAPAN

1. INTRODUCTION

The Japan Meteorological Agency (JMA) operates the RSMC Tokyo - Typhoon Center (RSMC: Regional Specialized Meteorological Center) based on a 1988 designation by the World Meteorological Organization (WMO). The Center provides information on tropical cyclones (TCs) in its area of responsibility (the western North Pacific and the South China Sea) to support disaster mitigation activities conducted by the NMHSs of ESCAP/WMO Typhoon Committee members. Such information includes the results of TC satellite image analysis issued in satellite report (SAREP) format shortly after observation times, as well as TC forecasts up to 72 hours ahead and TC track forecasts up to 120 hours ahead issued as RSMC TC advisories about 50 and 90 minutes, respectively, after observation times. Additionally, JMA provides domestic users with a variety of TC-related products such as hourly TC analysis results and 50-knot wind probability data when TCs of tropical storm (TS) intensity or higher are expected to approach Japan. All this information is based on TC analysis that has been continuously improved over more than half a century. Current operational procedures for TC analysis and related systems are outlined below, along with recent improvements and future plans for JMA.

2. OPERATIONAL PROCEDURES IN TROPICAL CYCLONE ANALYSIS

2.1 Tropical Cyclone Classification

TCs in the western North Pacific and the South China Sea are classified in the Typhoon Committee Operational Manual as follows:

Typhoon (TY):	TC with MSW of 64 knots or more
Severe tropical storm (STS):	TC with MSW between 48 and 63 knots
Tropical storm (TS):	TC with MSW between 34 and 47 knots
Tropical depression (TD):	TC with MSW of 33 knots or less

(MSW: maximum sustained winds averaged over the past 10 minutes)

To enable the provision of early warnings of TS formation, JMA analyzes TDs that are expected to reach TS intensity or higher within 24 hours (ExpT) and reports the results as an RSMC Tokyo TC advisory. In addition, TDs with maximum sustained winds (MSW) between 28 and 33 knots (Beaufort scale 7) are categorized as warning-issued TDs (WTDs), and are shown in marine warnings as well as in JMA's Asia-Pacific surface analysis charts. Conversely, those with an MSW value of less than 28 knots are categorized as no-warning-issued TDs (NTDs), and are shown in JMA's Asia-Pacific surface analysis charts only. Low-pressure systems with no definite surface cyclonic wind circulation are categorized as low-pressure areas (LPAs).

2.2. Operational Tropical Cyclone Analysis

To maximize the accuracy of TC intensity analysis, meteorological data such as those from surface observations (SYNOP, SHIP and BUOY), satellite products of geostationary and polar-orbiting satellites (including scatterometer-derived wind data) and NWP (numerical weather prediction) outputs are fully utilized by JMA (Figure 1).

Figure 2 shows a timeline of JMA's operational TC analysis, which starts with satellite analysis, that is early-stage Dvorak analysis (EDA) for TCs in the generation stage or conventional Dvorak analysis for those in the developing or mature stages. After Dvorak analysis with MTSAT images for a certain observation time, comprehensive analysis using other data such as those from surface and ship observations is carried out. Through consistency checking with weather map analysis, estimated TC parameters are fixed and reported in the form of a TC advisory about 50 minutes after the observation time. Even after the issuance of a TC advisory, the TC parameters are reviewed and updated with delayed observation information such as ASCAT data until the next analysis time.

Appendix C: Satellite Analysis Procedures in Operational Centers

Figure 3 shows a timeline of TC post-analysis. Reanalysis is carried out with further review of Dvorak analysis considering the TC life stages overall and with all available data, including additional information received later. The TC parameters finally fixed through post-analysis are disseminated via WMO GTS as RSMC Tokyo best-track bulletins about six weeks after a TC dissipates. For TCs reaching TS intensity or higher, TC post-analysis is carried out during the period from TD formation to TD dissipation, transformation to an extratropical cyclone, or movement outside the area of responsibility. Other TDs and LPAs are also post-analyzed for the finalization of JMA's surface weather charts.

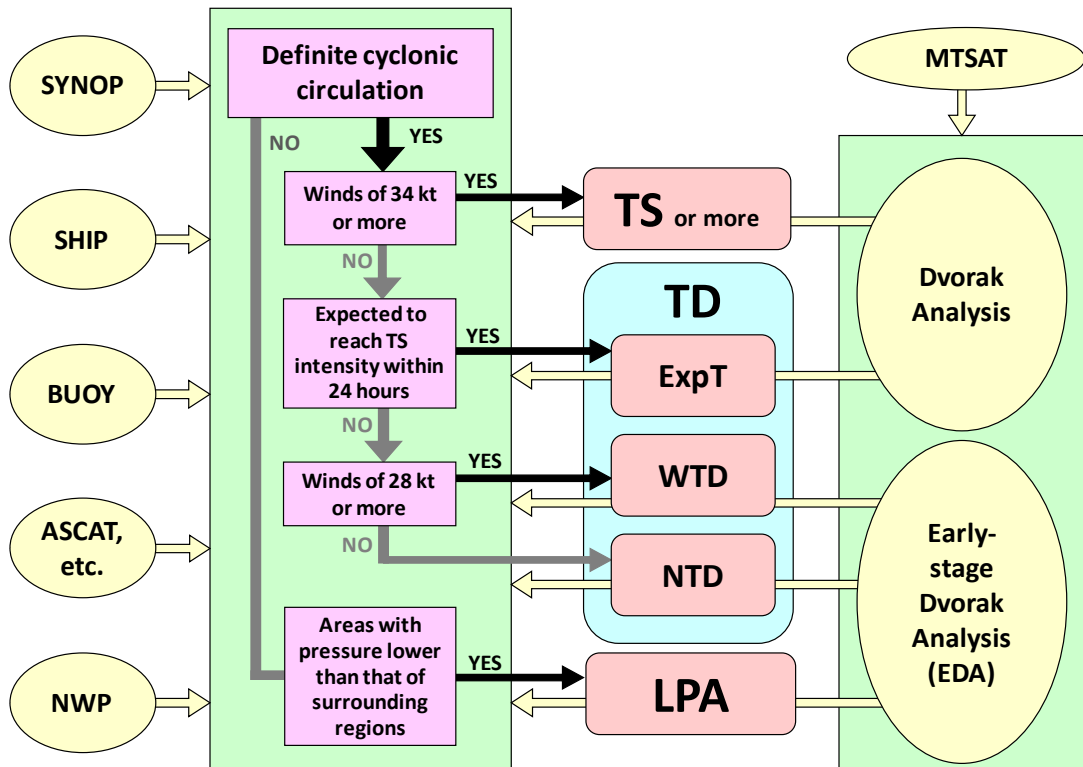

Figure 1 Flow chart of operational tropical cyclone analysis

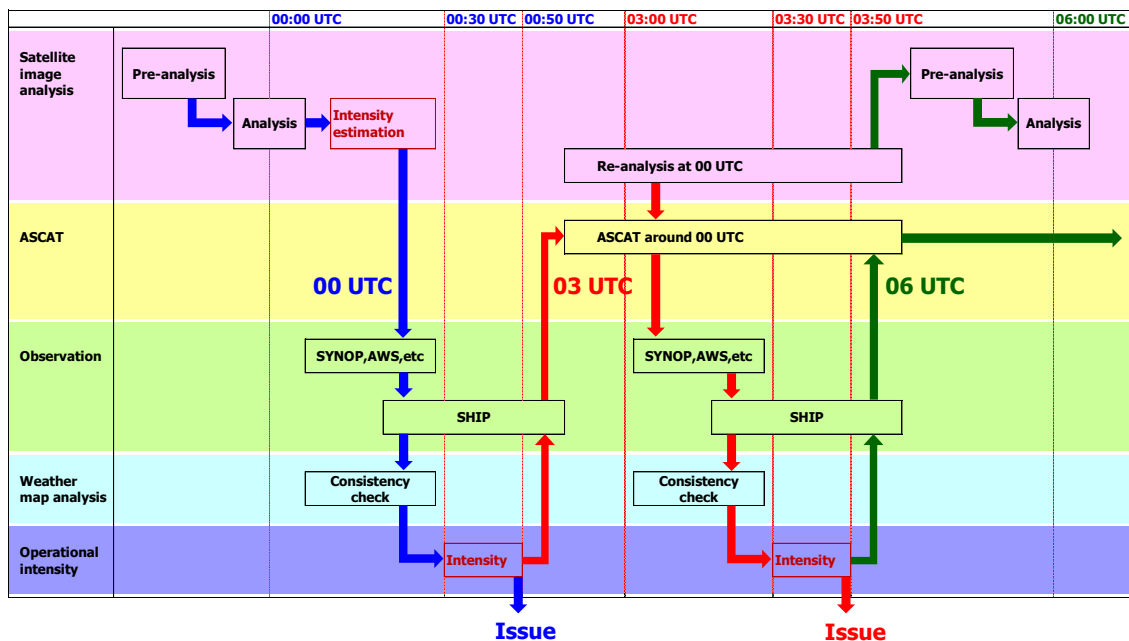

Figure 2 Timeline of operational tropical cyclone analysis

Appendix C: Satellite Analysis Procedures in Operational Centers

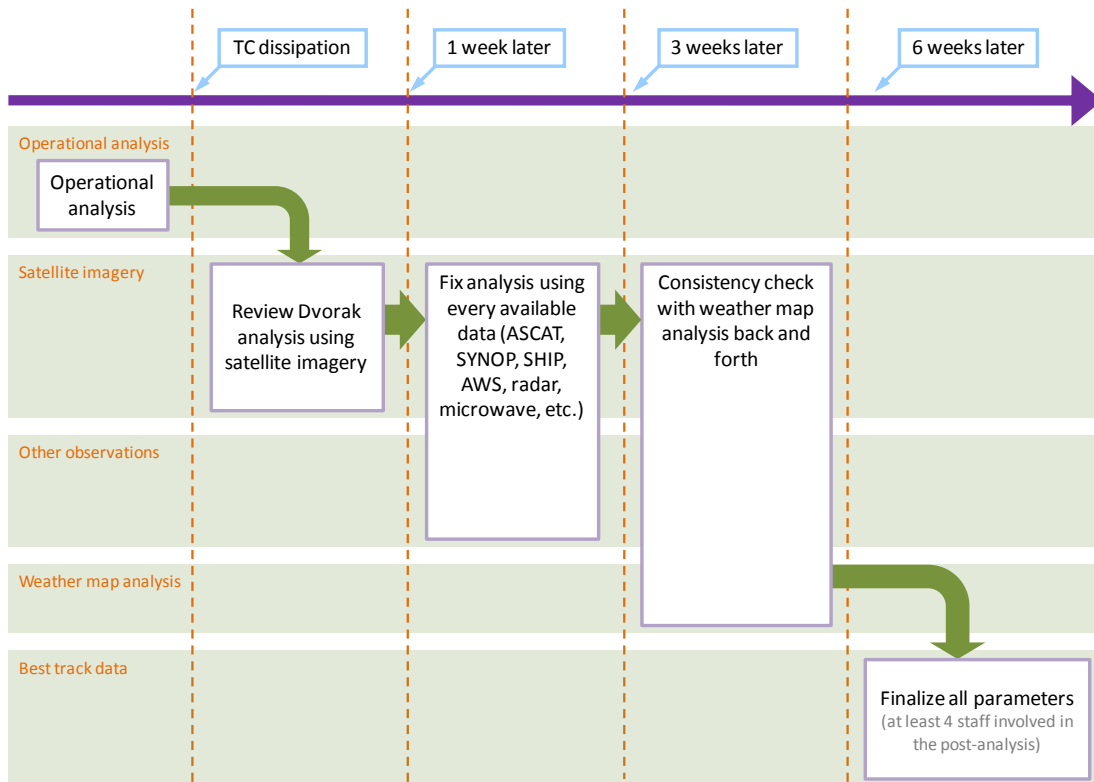

Figure 3 Timeline of tropical cyclone post-analysis

2.3. Dvorak Analysis

In 1984, JMA began operational Dvorak analysis based on Dvorak (1982) for the issuance of satellite reports (SAREPs). However, reconnaissance aircraft observations remained as the major source of data for TC intensity estimation until their termination in August 1987.

Since the introduction of the man-machine Dvorak analysis system in March 1987, the Dvorak (1984) EIR method has been adopted for JMA's operational TC intensity analysis. JMA uniquely uses a table for conversion from the Dvorak CI number to central pressure (CP) or MSW values as proposed by Koba et al. (1991) (hereafter referred to as the Koba table; Table 1), and estimation of decreasing CI numbers after landfall by Koba et al. (1989) (hereafter referred to as the landfall rule). These methods were introduced into JMA's operations after verification using JMA best-track data and CI numbers reanalyzed using the Dvorak (1984) EIR method over a period of six years during a reconnaissance period in the 1980s to maintain consistency between the periods before and after the termination of aircraft observation. The Koba table came into operation in 1989 together with the landfall rule after the introduction of a provisional table in 1987. The landfall rule, obtained from the study of 13 typhoons passing over the Philippines from 1981 to 1986, consists of the following observations:

- 1) When a developing TC makes landfall and the T number decreases immediately, the CI number also decreases immediately (Figure 4).
- 2) When a TC makes landfall within 12 hours after reaching its peak T number, and the T number continues to decrease, the corresponding CI number decreases at the same rate.
- 3) When a TC shows signs of redevelopment after 1) or 2) is applied, determination of the CI number follows the original Dvorak rule.

Although aircraft observation was terminated in 1987, continuous verification of the Koba table and the landfall rule have been carried out utilizing observational data for TCs passing over the Japanese islands or those from aircraft observation conducted during field experiments such as T-PARC and ITOP. Figure 5 compares CI numbers and observation data (MSLP or minimum

Appendix C: Satellite Analysis Procedures in Operational Centers

sea level pressure and MSW observed on the islands or by aircraft) from 1995 to 2010. The results indicate good performance for the estimation of CP and MSW using the Koba table.

CI num.	MSLP(hPa)	MWS(kt)
1.0	1005	22
1.5	1002	29
2.0	998	36
2.5	993	43
3.0	987	50
3.5	981	57
4.0	973	64
4.5	965	71
5.0	956	78
5.5	947	85
6.0	937	93
6.5	926	100
7.0	914	107
7.5	901	115
8.0	888	122

Table 1 Table for conversion from CI numbers to MSLP or MSW by Koba et al. (1989).
Operationally, margin for error associated with Dvorak analysis is considered.

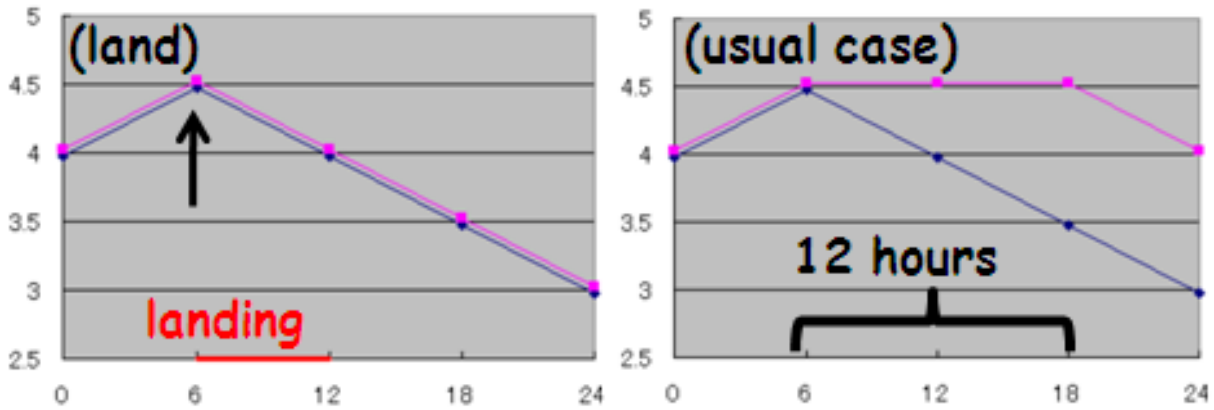
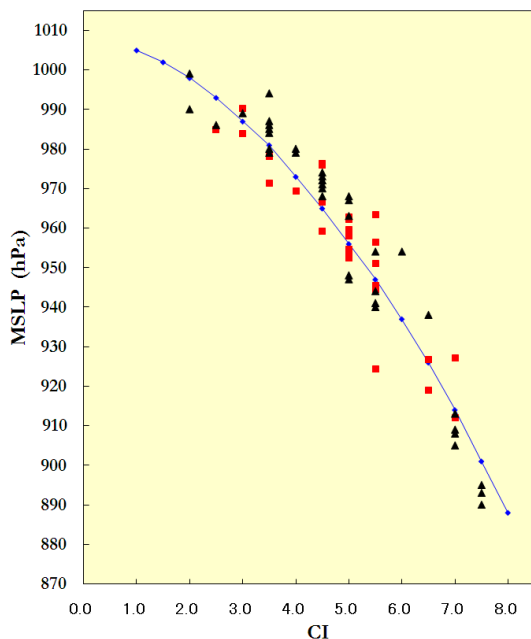

Figure 4 Example of post-landfall CI numbers (Koba et al., 1989, left).

The blue lines show T numbers and pink lines show CI numbers.

MSLP vs. CI from 1995 to 2010



MSW vs. CI from 1995 to 2010

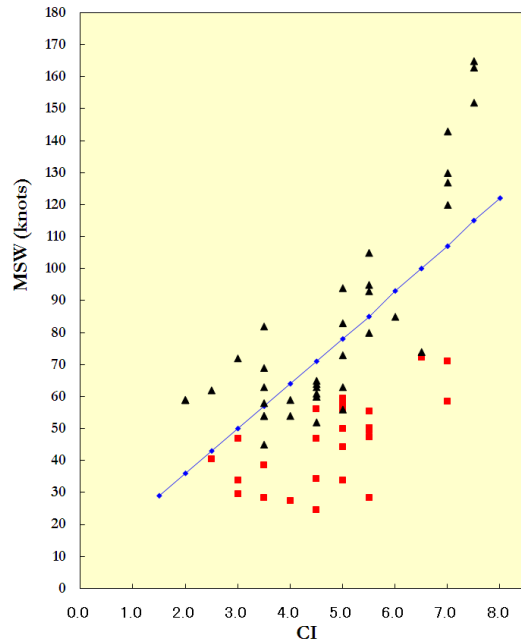

Figure 5 Verification (comparison of CI numbers and observation values)

The figures on the left and right show MSLP vs. CI and 10-minute MSW vs. CI, respectively. The red squares represent observations on the islands, and the black triangles indicate aircraft observation values recorded during T-PARC and ITOP. The blue lines show conversion using the Koba table. Note that aircraft observation values refer to minimum sea level pressures and maximum surface winds (SFMR estimations) in vortex messages.

2.4. Early-stage Dvorak Analysis (EDA)

JMA has used early-stage Dvorak analysis (EDA) operationally since 2001 to detect and classify TCs in weather map analysis and determine the likelihood of their development to TS intensity (Figure 1). EDA consists of three steps: detection of an organized convective cloud system (OCCS), classification of T numbers from 0.0 to 1.0 (T0.0/T0.5/T1.0), and classification of T1.5/T2.0 (Figure 6).

The first step of EDA is the detection of an OCCS – a convective cloud system with a cloud system center (CSC). The CSC features proposed by Tsuchiya et al. (2001) as shown in Table 2 are used for detection to supplement those of Dvorak (1984), which use animated satellite imagery.

The next step of EDA involves identifying the number of relevant features in the OCCS (Table 3). Systems with five features are classified as T1.0, those with four are classified as T0.5, and those with fewer than four are classified as T0.0 (Kishimoto 2008). After development to T1.0, OCCS classification as T1.5 or 2.0 is conducted with respect to the time variation in TC organizational factors such as the curvature and length of convective curved bands and the cyclonic rotation of convective cloud areas (Kishimoto et al. 2007). It should be noted that this classification is based on the pattern T-number (PT) chart of Dvorak (1984) to ensure continuity with the conventional Dvorak analysis in the next stage.

T numbers in EDA are set to provide criteria for TC classification indicating the likelihood of NTDs or WTDs at the time and the prospect of their development to TS intensity in the future (Kishimoto 2008). A TC in the early developing stage is first analyzed via T-number diagnosis using EDA. This analysis is followed by final TC classification using other data such as those of surface observations, ASCAT data and NWP outputs in a comprehensive manner.

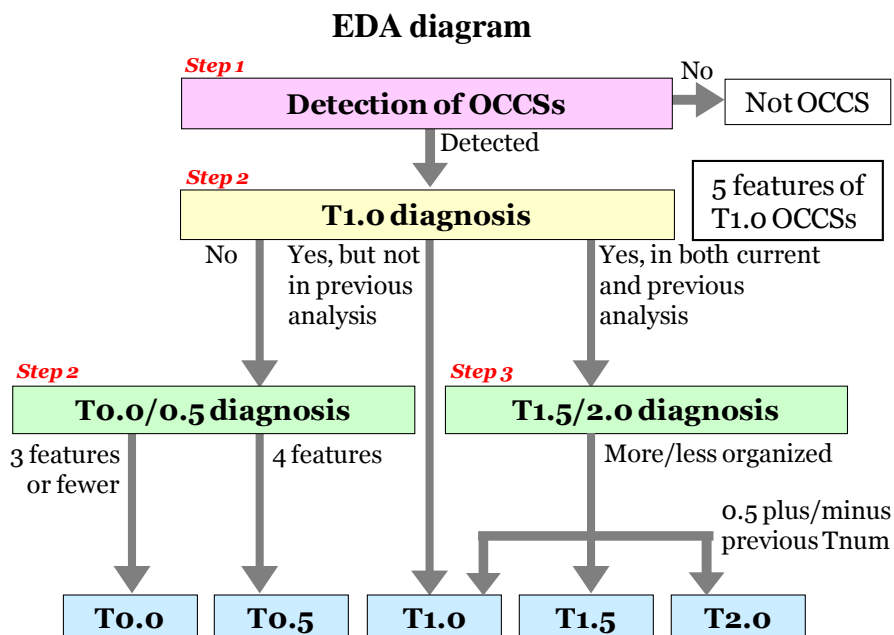

Figure 6 Outline of EDA

Appendix C: Satellite Analysis Procedures in Operational Centers

	Tsuchiya et al. (2001)	Dvorak (1984)
1	Curved band, a dense (-31°C or colder) overcast band that shows some curvature around a relatively warm (cloud minimum) area. It should curve at least one-fifth the distance around a 10° log spiral. Cirrus, when visible, will indicate anticyclonic shear across the expected CSC.	
2	Curved cirrus lines indicating a center of curvature within or near a dense, cold (-31°C or lower) overcast.	
3	Curved low cloud lines showing a center of curvature within 2° of a cold (-31°C or lower) cloud mass.	
4	Cumulonimbus clusters rotating cyclonically in animated imagery	None

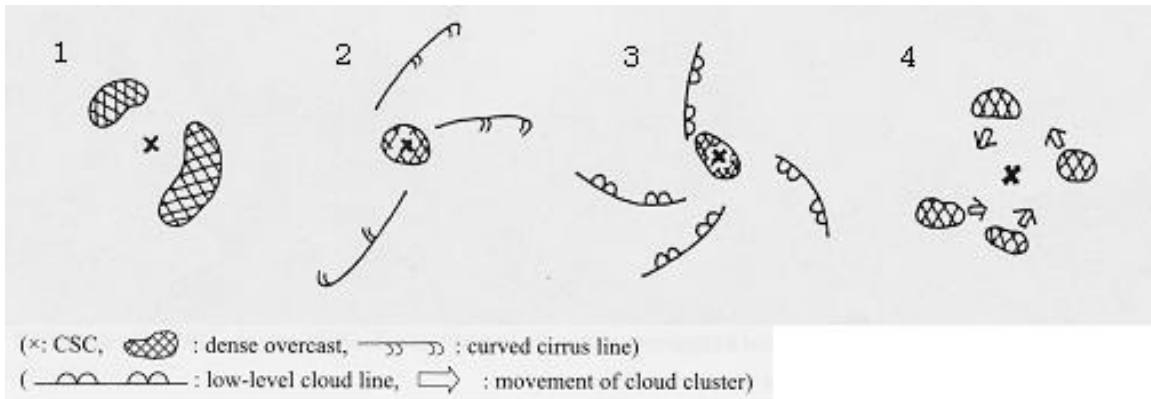

Table 2 CSC features of Tsuchiya et al. (2001) (left) and Dvorak (1984) (right). The lower figure illustrates the CSC features proposed by Tsuchiya et al.

	Tsuchiya et al. (2001)	
1	A convective cloud system has persisted for 12 hours or more.	
2	The cloud system has a CSC defined within a diameter of 2.5° latitude or less.	
3	The CSC persists for 6 hours or more.	
4	The cloud system has an area of dense, cold (-31°C or colder) overcast that appears less than 2° latitude from the center.	
5	The above overcast has a diameter of more than 1.5° latitude.	

Table 3 Features of OCCSs determined as T1.0. The figure on the right shows an OCCS determined as T1.0.

2.5. Microwave Analysis

TC pattern recognition, eye analysis and measurement of eye size using Aqua/AMSR-E 89 GHz and 36 GHz channels were studied (Asano et al. 2008). Supplemental estimation of TC center positions based on this imagery is now operational, and ASCAT data have been used since 2007 to determine 30- and 50-knot radii and identify TSs (TCs with MSW values of 34 knots or more). Data with rain flags or those showing values of more than 50 knots are rejected for MSW estimation.

3. SATELLITE ANALYSIS SYSTEM

JMA has developed a system called SATAID (Satellite Animation and Interactive Diagnosis) that allows forecasters to monitor and analyze satellite images not only for daily weather analysis but also for Dvorak and EDA TC analysis. The system is equipped with a variety of functions, including the following:

1) For monitoring and analysis of observation data

- Easy interface for TC analysis considerations such as estimation of center position, cloud system, movement and intensity (Data T number (DT)/Model Expected T number (MET)/Pattern T number (PT), final T number and CI number), and for the issuance of SAREP (Figure 7)
- Data overlays (various observations such as those made by satellite, SYNOP, SHIP, TEMP, METAR, AWS, radar, wind profiler, dropsonde, etc.) and vertical cross sections made with microwave sounders and NWP outputs to enhance understanding of TC structures
- Support for estimation of center position and intensity using surface data from the area surrounding the TC (compass method)
- Animation to clarify the development of TCs increasing the accuracy of short-range extrapolation prediction

2) For support of forecasts with highly functional display

- Sequential animations and arbitrary vertical cross-section charts of NWP outputs
- Drawing function for effective sharing of analysis and messages by forecasters

3) For post-analysis and OJT

- Use as a training resource with archived satellite imagery, observations and prediction data for typical weather conditions that may result in disasters

To deal with the large amounts of data expected in the future (e.g., those from next MTSAT and various polar-orbiting satellites), a version of SATAID for a 64-bit OS (GSMLPT64) has been developed and installed. This enhanced version allows processing of greater amounts of data, thereby enabling larger areas to be displayed with a higher spatial resolution of up to 100 m as well as the superimposition and composition of multiple images using up to 16 channels.

In addition to handling geostationary satellite imagery of MTSAT VIS, IR, SP and WV, the SATAID system enables the display and overlay of other satellite data such as those from AMSR-E, SSMIS, TMI, AMSU and ASCAT of Aqua, DMSP, TRMM, NOAA and MetOp. These new data can be displayed on the SATAID screen and in operational use.

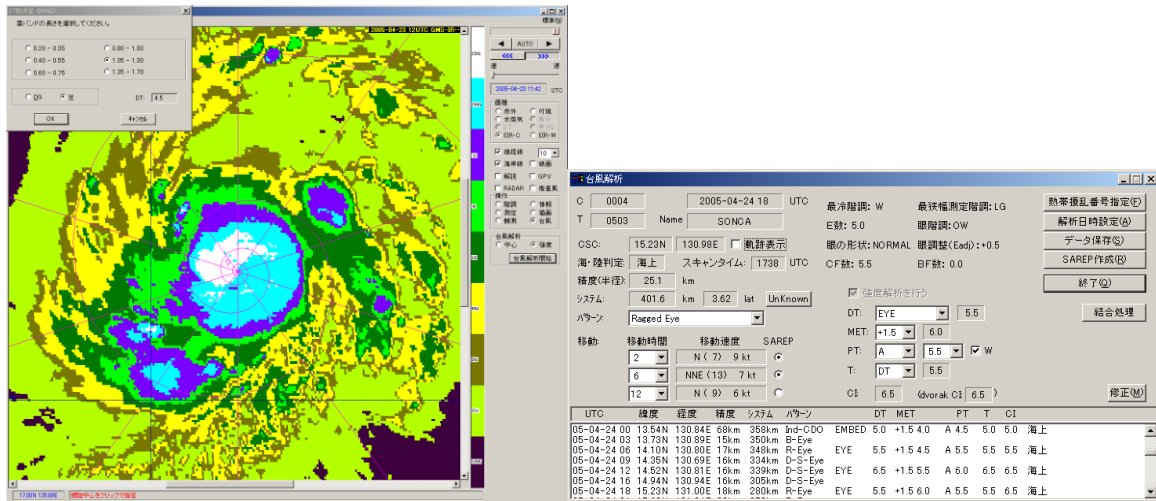

Figure 7 Example of intensity (DT number) estimation on the SATAID display.

4. FUTURE PLANS

4.1. Objective Microwave Analysis

JMA plans to introduce the elements of microwave analysis outlined below in the next few years. With manual provision of the CSC position, these estimations can be automatically executed to obtain results.

- MSW estimation using multi-channel microwave imager data based on the study of Hoshino and Nakazawa (2007) (Figure 8 (a))
- Central pressure estimation using multi-channel microwave sounder data based on the study of Bessho et al. (2010) as a method for detecting warm cores (Figure 8 (b))
- Use of the CIMSS AMSU intensity algorithm as a method for converting warm-core values to central pressure data
- Implementation of a method for estimating 30- and 50-knot radii and MSW using 7- and 10-GHz-band imagery from AMSR-E based on the study of Saitoh and Shibata (2010) (Figure 8 (c))

MSW estimation based on Hoshino and Nakazawa (2007) has been verified. The results show a close correlation with the best track data of RSMC Tokyo (Yoshida et al. 2011).

4.2. Objective Dvorak Analysis

Cloud grid information objective Dvorak analysis (CLOUD) is currently being developed by JMA. The unique points of CLOUD are that it covers both EDA and Dvorak analysis and that it can be used with cloud grid information (CGI) – an objective cloud product operationally prepared by JMA since June 2005 (<http://mscweb.kishou.go.jp/product/product/cgi/index.htm>). CI number estimation can be automatically performed after manually fixing three parameters (CSC position, its accuracy and cloud pattern) applying the features of cumulonimbus (Cb) clusters of CGI with the extent and brightness temperature to EDA and the Dvorak rules (Figure 8 (d)). The method has been provisionally verified and shown to have a level of accuracy comparable to those of manual EDA and Dvorak analysis (Kishimoto 2011).

4.3. Objective Satellite Analysis System

JMA has installed prototypes of the above five objective methods on SATAID. These methods will become operational in a few years. Future procedures in TC analysis using SATAID will be as follows:

Appendix C: Satellite Analysis Procedures in Operational Centers

- 1) Determination of CSC position, position accuracy and cloud patterns will be carried out on SATAID manually.
- 2) SATAID will automatically make MSW and CP estimations using CLOUD and objective microwave analysis, and will display all the results at once.
- 3) Considering these estimates and other observational data, forecasters will be able to determine TC intensity.

(a)

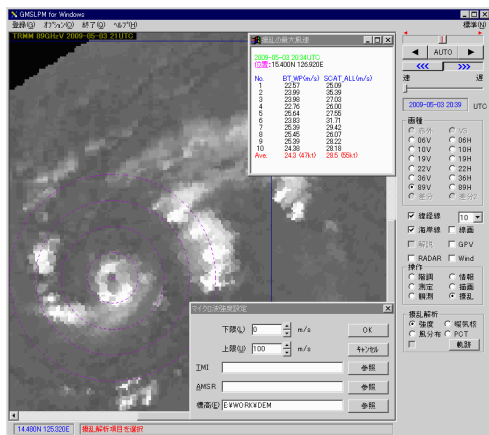

(b)

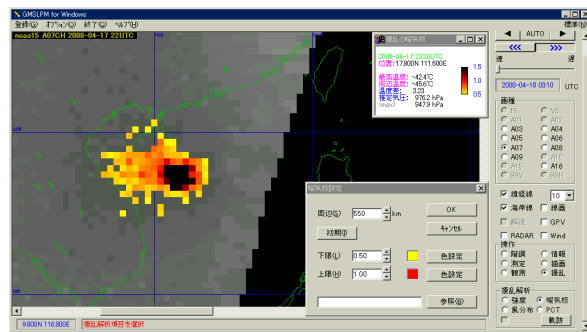

(c)

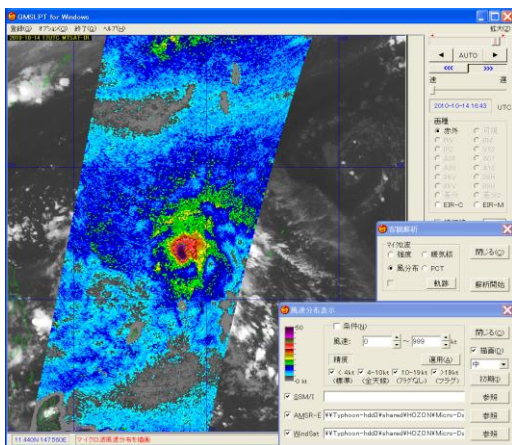

(d)

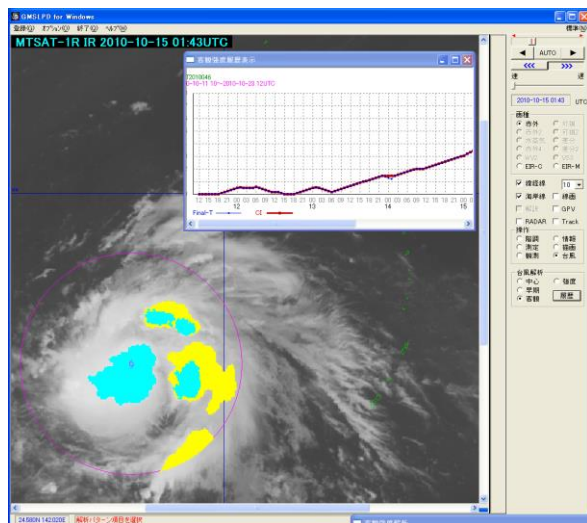

Figure 8 Examples of objective TC analysis system

- (a) MSW estimation using multi-channel microwave imager data
- (b) Central pressure estimation using multi-channel microwave sounder data
- (c) Wind distribution estimation using 7- and 10-GHz-band data of AMSR-E
- (d) Cloud grid information objective Dvorak analysis

REFERENCES

- Asano J., S. Nishimura, K. Kato, K. Mouri, S. Saitoh, S. Yoshida, T. Endo, K. Ootubo, A. Shimizu and R. Oyama, 2008: Analysis of Tropical Cyclones Using Microwave Satellite Imagery, RSMC Tokyo - Typhoon Center Technical Review, No. 10, 30 – 70.
- Bessho K., T. Nakazawa, S. Nishimura, K. Kato, 2010: Warm core structures in organized cloud clusters developing or not developing into tropical storms observed by the Advanced Microwave Sounding Unit. *Mon. Wea. Rev.*, 138, 2624 – 2643. doi: 10.1175/2010MWR3073.1.
- Dvorak V. F., 1982: Tropical cyclone intensity analysis and forecasting from satellite visible or enhanced infrared imagery. NOAA NESS, Applications Laboratory Training Notes.
- Dvorak V. F., 1984: Tropical cyclone intensity analysis using satellite data. NOAA Tech. Rep. 11.
- Hoshino S. and T. Nakazawa, 2007: Estimation of Tropical Cyclone's Intensity Using TRMM/TMI Brightness Temperature Data, *J. Meteor. Soc. of Japan*, Vol. 85, No. 4, 437 – 454.
- Kishimoto K., T. Nishigaki, S. Nishimura and Y. Terasaka, 2007: Comparative Study on Organized Convective Cloud Systems Detected through Early Stage Dvorak Analysis and Tropical Cyclones in Early Developing Stage in the Western North Pacific and the South China Sea, RSMC Tokyo - Typhoon Center Technical Review No. 9, 19 – 32.
- Kishimoto K., 2008: Revision of JMA's Early Stage Dvorak Analysis and Its Use to Analyze Tropical Cyclones in the Early Developing Stage, RSMC Tokyo - Typhoon Center Technical Review No. 10, 1 – 12.
- Kishimoto K., 2011: Verification of objective intensity analysis for TCs using cloud grid information objective Dvorak analysis (CLOUD), personal note (in Japanese).
- Koba, H., S. Osano, T. Hagiwara, S. Akashi, and T. Kikuchi, 1989: Determination of the intensity of typhoons passing over the Philippines (in Japanese). *J. Meteor. Res.*, 41, 157 – 162.
- Koba H., T. Hagiwara, S. Osano and S. Akashi, 1991: Relationships between CI Number and Minimum Sea Level Pressure/Maximum Wind Speed of Tropical Cyclones, *Geophysical Magazine*, Vol. 44, No. 1, 15 – 25.
- Saitoh S. and A. Shibata, 2010: AMSR-E All-Weather Sea Surface Wind Speed (in Japanese), *Tenki* Vol. 57, No. 1, 5 – 18.
- Tsuchiya, A., Mikawa, T. and Kikuchi, A., 2001: Method of Distinguishing Between Early Stage Cloud Systems that Develop into Tropical Storms and Ones that Do Not, *Geophysical Magazine Series 2*, Vol. 4, Nos. 1 – 4, 49 – 59.
- Yoshida S., M. Sakai, A. Shouji, M. Hirohata, A. Shimizu, 2011: Estimation of Tropical Cyclone Intensity Using Aqua/AMSR-E Data, RSMC Tokyo - Typhoon Center Technical Review No. 13, 1 – 36.

SATELLITE ANALYSIS PROCEDURES IN AUSTRALIAN TCWCs

Improved standardisation of practices in the last 5 years:

- Standardisation of P-W relationships
- Improved training materials
- National trainer appointed
- Increased exchange of forecasters during events

Variations to Dvorak 1984:

- Electronic spreadsheet incorporating notes and with potential for error checking
- Use of 3 hour average DT, especially for shear and EIR eye patterns
- Enhanced Flow Diagrams
- Flexibility in assigning Shear pattern DT based on Dvorak 1995
- Tendency to discount EMBD Center DTs
- Modified CI rules (6 hour weakening instead of 12 hour, based on Brown and Franklin 2004)
- Discretionary assignment of maximum wind in 5 knot increments
- 10-minute wind (0.88 conversion factor)
- Knaff-Zehr-Courtney Wind-Pressure relation
- Final operational intensity estimate not bound to CI
- ADT, AMSU & SATCON routinely accessed via internet.
- Subjective Dvorak estimates from other agencies (SAB and JTWC) routinely accessed.

Excerpt from BoM Forecast Process Wiki:

3.6. Review Dvorak analysis.

If there is any doubt about the current analysis it may be necessary to check previous estimates to ensure current estimate is appropriate.

- Check [Advanced Dvorak Technique](#). ([ADTNotes](#))
 - Compare with [PGTW Dvorak bulletin](#), [JTWC analysis/forecast policy](#), [SAB Dvorak analysis](#)
 - Review other intensity guidance [CIMSS AMSU](#), [CIMSS Satcon](#), [CIRA AMSU](#)
- Scatterometry used for “minimum-maximum”
 - Subjective assessment of microwave imagery.
 - Wind intensity assigned in 5 knot increments
 - Final intensity estimate may be biased on the high side of available guidance when systems are threatening communities or expected to undergo rapid intensification. (Does not apply to best tracking)

Appendix C: Satellite Analysis Procedures in Operational Centers

BoM CI – Wind chart

CI	10 min mean winds		Gusts		Severity Category	Comments	
	km/h	knots	km/h	knots			
1.0	35	20	80	45	Tropical Low		
1.5	45	25	80	45			
2.0	45	25	80	45			
2.5	55	30	80	45			
3.0	65	35	90	50	Category 1	Damaging gusts 90-124km/h Gale force mean 34-47 knots	
3.0	75	40	100	55			
3.0	85	45	120	65			
3.5	95	50	130	70	Category 2	Destructive gusts 125-164km/h Storm force mean 48-63 knots	
4.0	100	55	150	80			
4.0	110	60	155	85			
4.5	120	65	170	90	Category 3	Gusts 165-224 km/h	Very Destructive gusts >164km/h force mean > 63 knots Hurricane
4.5	130	70	185	100			
4.5	140	75	195	105			
5.0	150	80	215	115			
5.0	155	85	220	120	Category 4	Gusts 225-279 km/h	
5.5	165	90	230	125			
5.5	175	95	250	135			
6.0	185	100	260	140			
6.0	195	105	275	150	Category 5	Gusts >279 km/h	
6.5	205	110	285	155			
6.5	215	115	295	160			
7.0	220	120	315	170			
7.0	230	125	325	175			
7.5	240	130	345	185			
7.5	250	135	350	190			
7.5	270	145	380	205			
8.0	280	150	390	210			

Dvorak Enhanced Infrared (EIR) Analysis Diagram

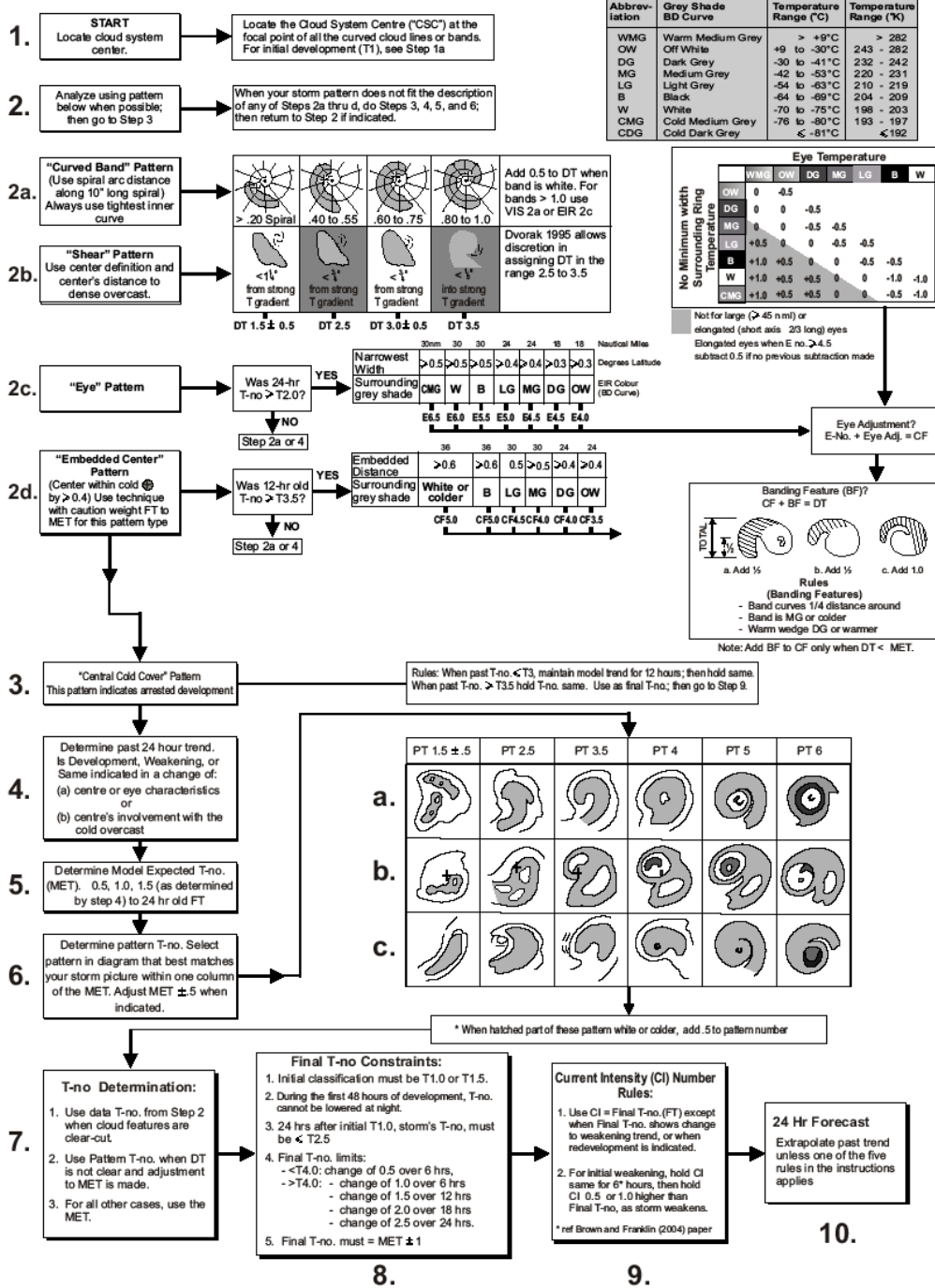

Source: Dvorak, V.F. 1995 Tropical clouds and cloud systems observed in satellite imagery: Tropical cyclones. Workbook Vol. 2. Modified by Perth Tropical Cyclone Warning Centre, Bureau of Meteorology, towowa@bom.gov.au. Arwork held: Publication Section, Bureau of Meteorology. Date: 6 October 2009.

Dvorak Visual (VIS) Analysis Diagram

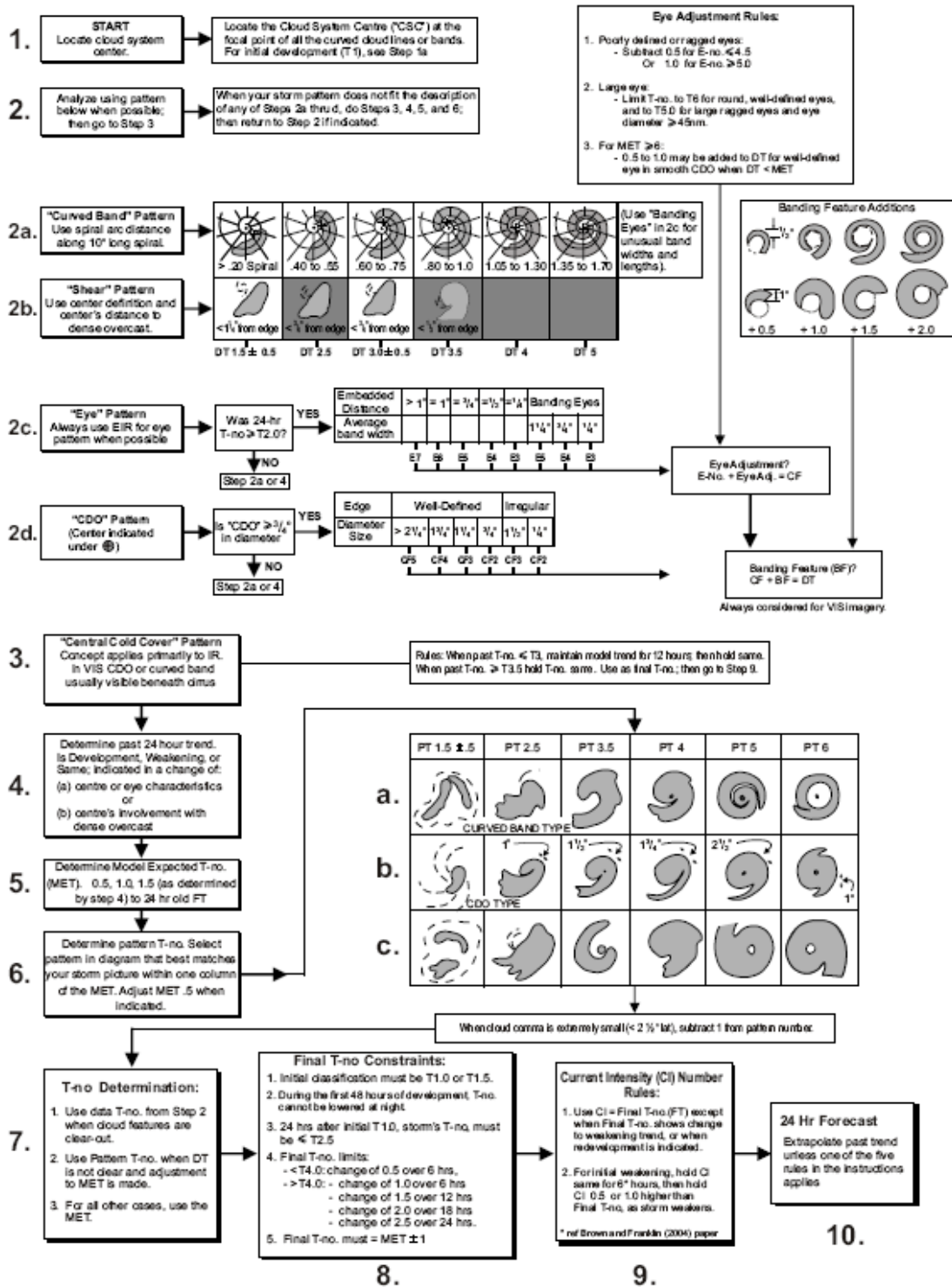

Source: Dvorak, V.F. 1983 Tropical clouds and cloud systems observed in satellite imagery: Tropical cyclones. Workbook No. 2. Modified by Pacific Tropical Cyclone Warning Centre, Bureau of Meteorology. dvorak@bom.gov.au. Airwork Field Publication Section, Bureau of Meteorology. Date: 6 October 2005.

Appendix C: Satellite Analysis Procedures in Operational Centers

Print (N/A)		MET Note 225				Gray Shade Code		EYE Pattern																		
		(BD Curve)																								
Time UTC	Step 1 Position		IR/VIS	Step 2A, 2B				Step 2C - EYE			Step 2D	Step 2E	DT Computation			AVG	Step 3	Step 4	Step 5	Step 6	Steps 7,8	Step 9	Step 10	Step 11		
	Lat. (S)	Lon. (E)		DT 1.5	DT 2.5	DT 3.5	DT 4.5	Embddd.	Surr.	Eno+Eadj=CF	CDO	Embddd Cntr.	Temp. (CF)	CF	BF	DT	DT	CCC	Trend	MET	PAT	FT	CI	FI		Number
10	0830		139.0																						Curvature of banding increa	
11	1130		138.6																							FT limited by rules
12	1430		138.2				0.4																			Curvature not as neatly defi
13	1730		137.8	IR/VIS	IR		0.5																			Curvature not as neatly defi
14	2030			VIS	VIS		0.5																			Curvature not as neatly defi
15	2330																									banding is very broken on v
16	2130	12.3	137.4	IR			0.5-0.6																			banding is very broken on v
17	2230	12.3	137.2	IR			0.5																			banding is very broken on v
18	2230			VIS			0.6																			banding is very broken on v
19	2330	12.3	136.5	IR			0.7-0.9																			banding is very broken on v
20	0030	12.6	136.0	VIS			0.8-0.9																			banding is very broken on v
21	0030			IR			0.7-0.9																			banding is very broken on v
22	0230	13.0	135.5				0.8																			banding is very broken on v
23	0430	13.3	134.9				0.8-1.0																			banding is very broken on v
24	0530	13.7	134.2				0.9																			banding is very broken on v
25	0530																									banding is very broken on v
26	0230	14.0	133.5	VIS&IR			0.9-1.0		DG	4.5	-0.5															banding is very broken on v
27	0230								DG	4.5	-0.5															banding is very broken on v
28	0530	14.1	132.7	VIS			1.1-1.2		MG	4.5	-0.5															banding is very broken on v
29	0530																									banding is very broken on v
30	0630	14.2	132.1	VIS			0.9																			banding is very broken on v
31	0630			IR			1.0-1.1																			banding is very broken on v
32	0630																									banding is very broken on v
33	0730	14.4	131.7	VIS			0.9-1.0																			banding is very broken on v
34	1730																									banding is very broken on v
35	2030	14.5	131.2						B	5.5	-0.5															banding is very broken on v
36	2030																									banding is very broken on v
37	2030																									banding is very broken on v
38	2330	14.7	130.8						LG	5.0	-0.5															banding is very broken on v
39	2330								B	5.5	-0.5															banding is very broken on v
40	0230	14.9	130.4						B	5.5	-0.5															banding is very broken on v
41	0330								B	5.5	-0.5															banding is very broken on v
42	0430								W	6.0	-0.5															banding is very broken on v
43	0530	15.4	130.0						B	5.5	-0.5															banding is very broken on v
44	0630								LG	5.0	-0.5															banding is very broken on v
45	0730								LG	5.0	0.5															banding is very broken on v
46	0830	15.8	129.7						MG	4.5	0.0															banding is very broken on v
47	0830																									banding is very broken on v
48	0930								LG	5.0	-0.5															banding is very broken on v
49	1030								LG	5.0	-0.5															banding is very broken on v
50	1130	16.3	129.3						MG	4.5	0.0															banding is very broken on v
51	1130																									banding is very broken on v
52	1230								LG	5.0	-0.5															banding is very broken on v
53	1330								MG	4.5	0.0															banding is very broken on v

USE OF DVORAK TECHNIQUE IN JAKARTA TCWC, INDONESIA

I. JAKARTA TCWC

Since 24th March 2008 Indonesia Meteorological Climatological and Geophysical Agency (BMKG) has been operating a Tropical Cyclone Warning Center in Jakarta (Jakarta TCWC). With reference to the WMO Tropical Cyclone Operational Plan for South Pacific and Southeast Indian Ocean (TCP 24), the Jakarta TCWC has responsibility to issue Tropical Cyclone Warning for area bounded by EQ 090°E, 10S 090°E, 10S 120°E, 11S 120°E, 11S 128°E, 09S 128°E, 09S 141°E, EQ 141°E, as highlighted in Image 1 below.

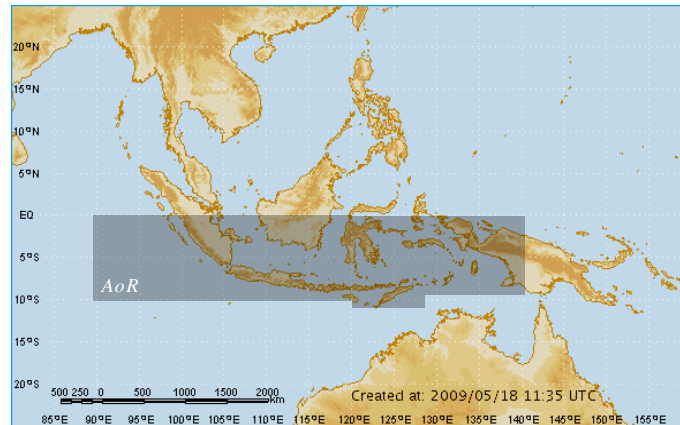

Image 1: Jakarta TCWC Area of Responsibility (dark shadow)

a. Operational Procedures / Guidance used in Jakarta TCWC

- Operational directive and forecaster duty list, adopted from Australian TCWC, developed and adjusted to conform with Jakarta TCWC local conditions
- Cyclogenesis checksheet, as the principal tool for cyclogenesis analysis
- CI-pressure-wind relations conversion table

b. Analysis and Forecasting Tools

There are 2 main tools in the Jakarta TCWC operational activities:

- TC Module, used for the product preparation and dissemination of tropical cyclone information
- Synergie, a beneficial integrated system of synoptic and upper air observation data, satellite imagery, and NWP model data which completed with a special cyclone module that is considered as Jakarta TCWC backup system.

Appendix C: Satellite Analysis Procedures in Operational Centers

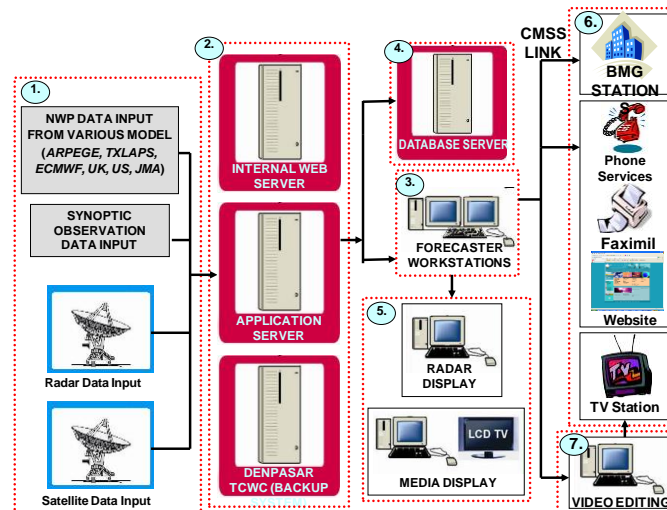

Operational Design of Jakarta TCWC

II. USE OF DVORAK TECHNIQUE IN JAKARTA TCWC

a. Local Variation to Dvorak Technique

Jakarta TCWC Area of Responsibility is located very near to equator that tropical disturbance occurred is mostly at the early stage development with disorganized cloud pattern. When the disturbance develops into tropical cyclone, it formed a relatively small-sized storm with relatively short lifetime (Cyclone KIRRILY in 2009, Cyclone ANGGREK in 2010).

b. Variation of Dvorak Technique Implementation between Forecasters

There are differences in the forecaster's approach due to irregular cloud pattern which commonly encountered in the early stage development. Differences in analysis result have become a necessity. This is especially occurred in determining the coordinates of the circulation center. Using microwave imagery, circulation centre issue is never arising. Though unavailability of this data may causes coordinates difference up to one degree.

c. Analysis Procedures Changes

During 3 years operational period of Jakarta TCWC, there has been no significant change in the operational procedure, especially related to the implementation of Dvorak method.

d. Final Intensity versus CI

So far, determination of final intensity always matches the CI.

e. Technology Advancement Influence Through Dvorak Technique

- Microwave imagery obtained from [NRL Tropics Site](#) website is very helpful in determining the circulation center in many pre-cyclone cases.
- Scatterometer wind from ASCAT is used to compare with maximum wind.
- Various products from RAMMB CIRA particularly satellite surface wind analysis, is also used as consideration. Though we are not use the Digital Dvorak since the value is often over estimated.

Appendix C: Satellite Analysis Procedures in Operational Centers

f. Ancillary Data

- Microwave imagery.
- Scatterometer wind.
- Satellite surface wind analysis.

g. CI – Pressure – Wind Relation Used

Jakarta TCWC used Dvorak Conversion Table for Perth TCWC as initial guidance. But during the operational period, it is noted that the central pressure of tropical cyclones occurred in Jakarta TCWC AoR tends to be bigger than pressure listed in the table. It is noted that the difference is ranging from 2 to 19 mb depending on the cyclone intensity. This was suspected due to they are located very close to the equator (<10 degrees south).

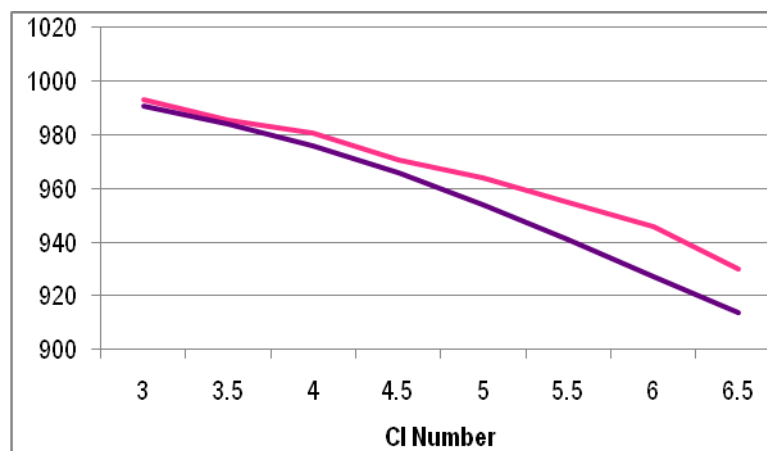

Comparison between central pressure of tropical cyclones occurred in the Jakarta TCWC Area of Responsibility (red) and central pressure in the Dvorak Conversion Table for Perth TCWC (purple).

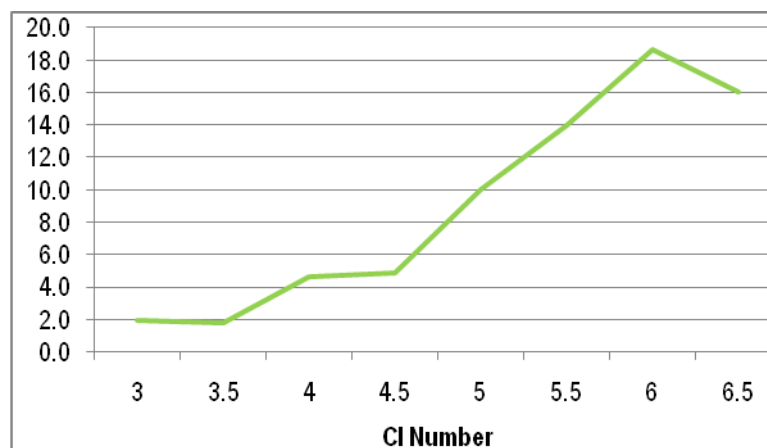

Difference between central pressure of tropical cyclones occurred in the Jakarta TCWC Area of Responsibility and central pressure in the Dvorak Conversion Table for Perth TCWC.

h. Best Track Records

No best track record has been produced by TCWC Jakarta so far.

OPERATIONAL PROCEDURES OF SATELLITE ANALYSIS ON TROPICAL CYCLONE IN CMA

Operational TC satellite analysis in China Meteorological Administration (CMA) is consisted of two parts: real time analysis conducted by National Meteorological Center of CMA (NMC/CMA) and post-season re-analysis conducted by an expert group leading by Shanghai Typhoon Institute of CMA (STI/CMA). The real time satellite analysis is performed 4 or 8 times daily according to the distance from TC center to China coast and serves as a main reference for the official TC positioning and intensity determination, which is also issued by NMC/CMA. The post-season re-analysis is performed 4 times daily for best-track dataset, which is released annually by CMA.

1. REAL TIME SATELLITE ANALYSIS

Real time satellite analysis in NMC/CMA is performed mainly on the Geostationary FY-2E and FY-2D. MTSAT is also frequently used for comparison and reference.

A simplified Dvorak technique is applied, consisting of the following steps:

a) Center location according to cloud pattern (Fig. 1).

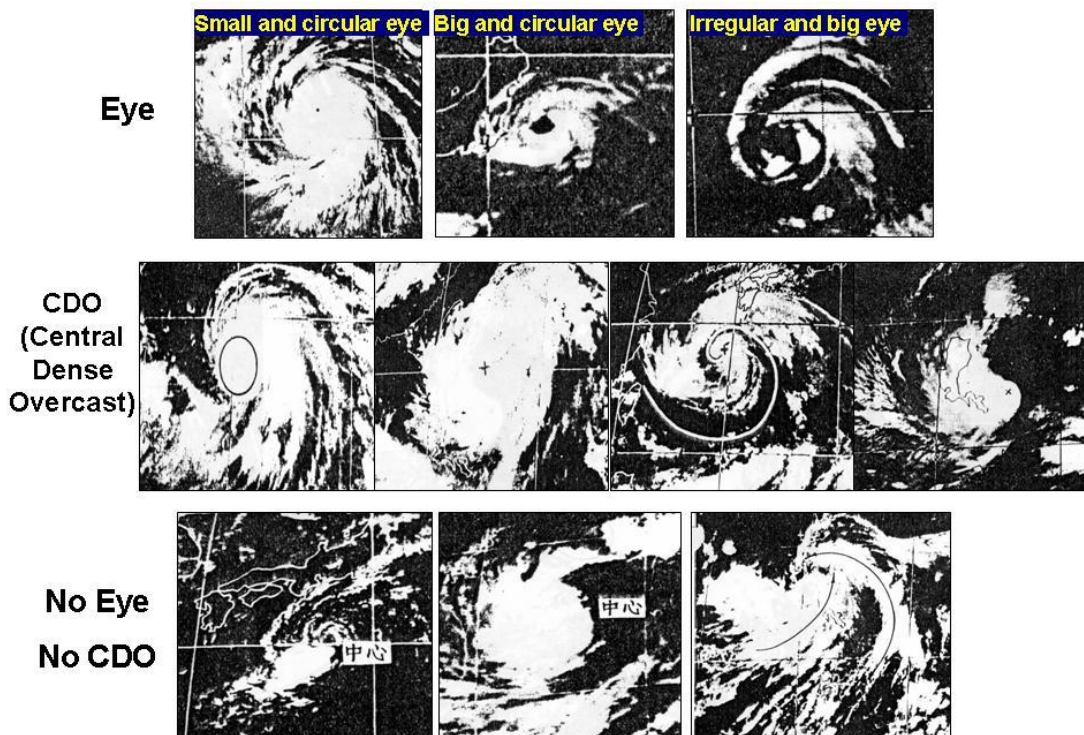

Fig. 1 Three types of cloud pattern

b) Determination of CI index

The Current Intensity (CI) index is composed of CCI, CBI and CDOI ($CI = CCI + CBI + CDOI$). CCI is the characteristic index of circulation center and determined based on the eye shape or the location of TC circulation center relative to the dense cloud region (Fig. 2a, 2b, 2c). CBI is the zonal characteristic index of cloud bands and determined based on spiral cloud bands and severe convective clouds near TC center (Fig. 3a and 3b). CDOI is the characteristic index of central dense overcast and determined based on mean value of longitudinal (north-south direction) and latitudinal distances (west-east direction) of central dense overcast in lat/lon degree (Fig. 4).

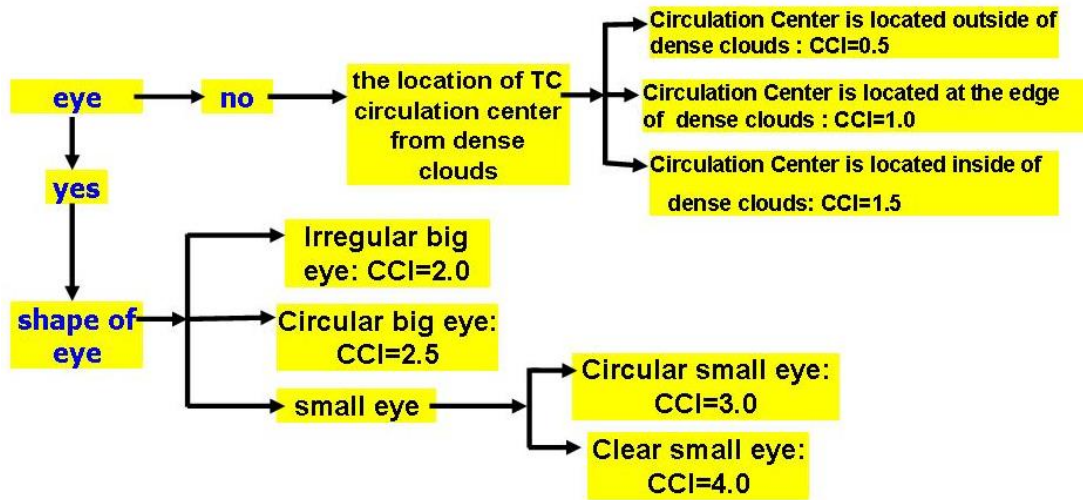

Fig. 2a Flowchart for CCI determination.

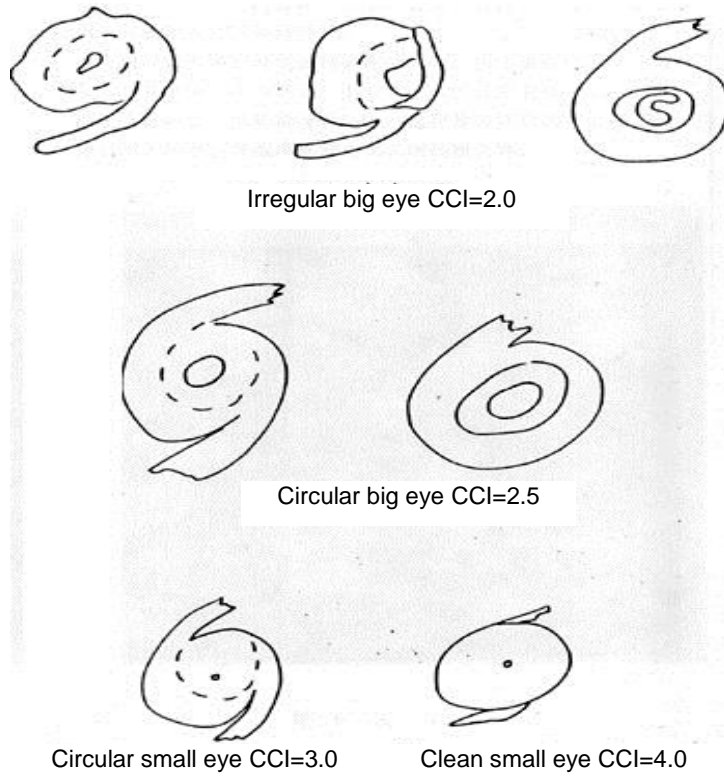

Fig. 2b Different eye shape and corresponding CCI.

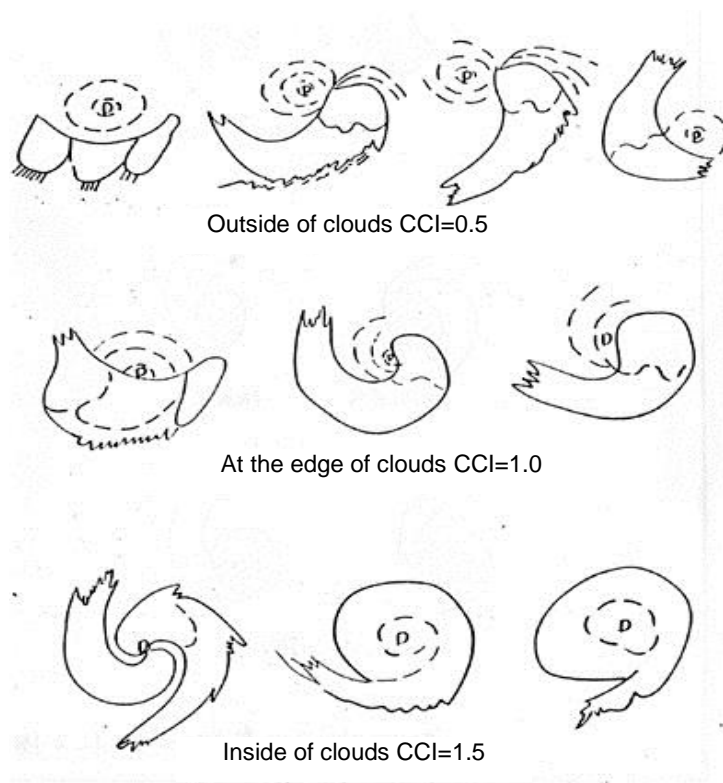

Fig. 2c CCI according to the location of TC circulation center relative to dense cloud region

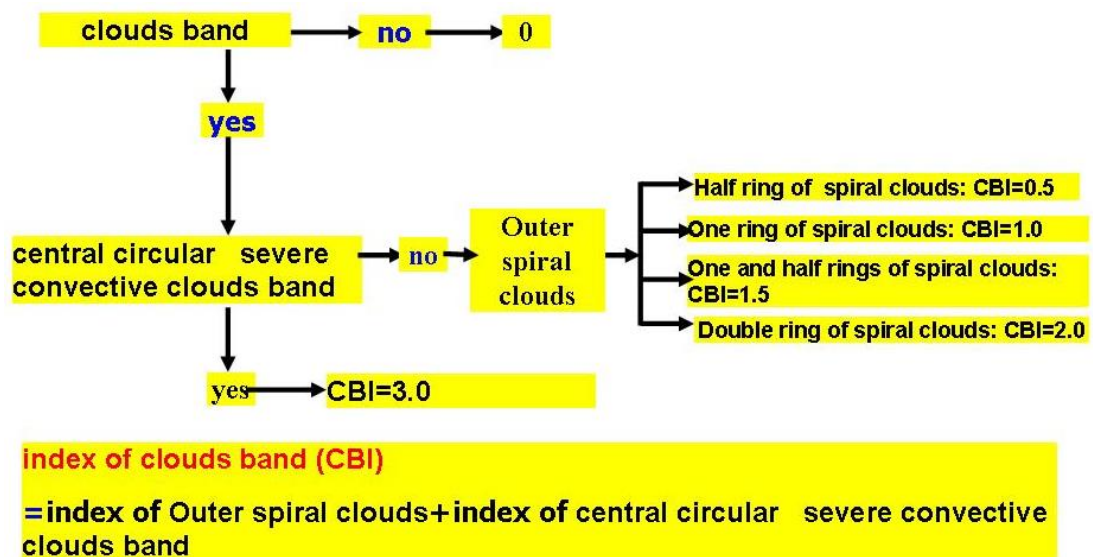

Fig. 3a Flowchart for CBI determination.

Appendix C: Satellite Analysis Procedures in Operational Centers

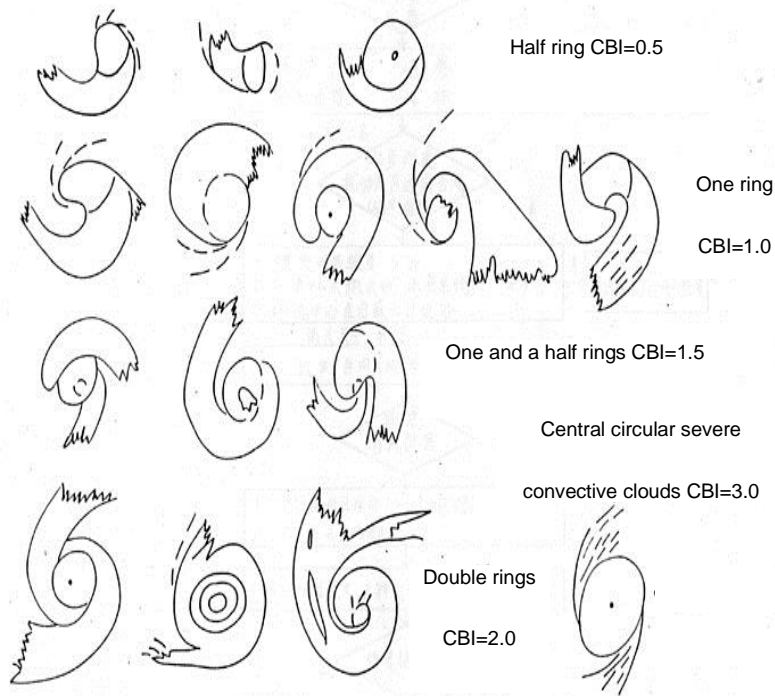

Fig. 3b Five types of spiral cloud bands and severe convective clouds near TC center and corresponding CBI.

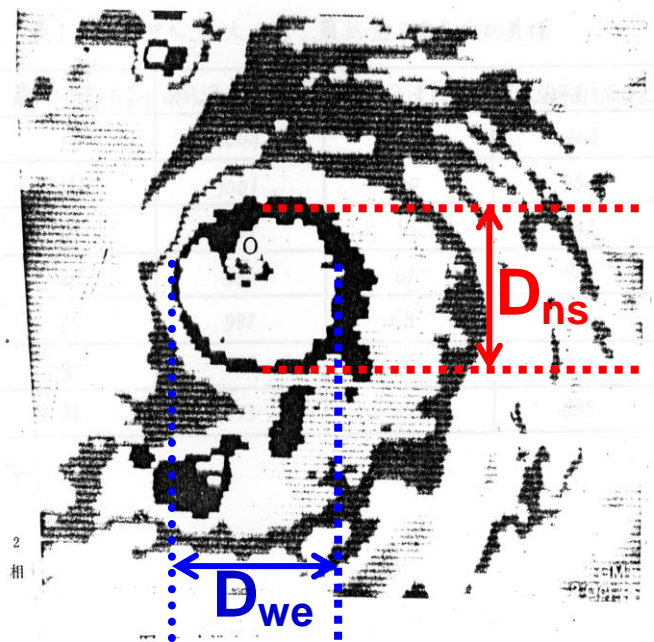

Fig. 4 Determination of CDOI. $CDOI = (D_{ns} + D_{we}) / 2$.

c) Determination of maximum mean wind speed and central pressure based on CI-pressure-wind relationship

The CI-pressure-wind relationship used in NMC/CMA is shown in Table 1.

Appendix C: Satellite Analysis Procedures in Operational Centers

Table 1 CI-pressure-wind relationship used in NMC/CMA

code	CI	Vmax (knots)	Vmax (m/s)	MSLP (hPa)
00	decrease			
15	1.5	25	13	1004
20	2.0	30	15	1001
25	2.5	35	18	997
30	3.0	45	23	989
35	3.5	55	28	984
40	4.0	65	33	978
45	4.5	77	39	969
50	5.0	90	46	959
55	5.5	102	52	948
60	6.0	115	59	933
65	6.5	127	65	920
70	7.0	140	72	906
75	7.5	155	79	894
80	8.0	170	87	882
99	Extratropical Transition			
//				

The Objective Typhoon Intensity Estimation System was introduced from CIMSS in 2009 and put into operational use in 2010. The system is now working with input information from FY2D/2E. Fig. 5 is an example of super typhoon Megi at 11:30UTC on October 17 2010. The center temperature is +7.1°C, the cloud region temperature is -76.7°C, CI is 7.0, MSLP is 899.9hPa, and Vmax is 140kt.

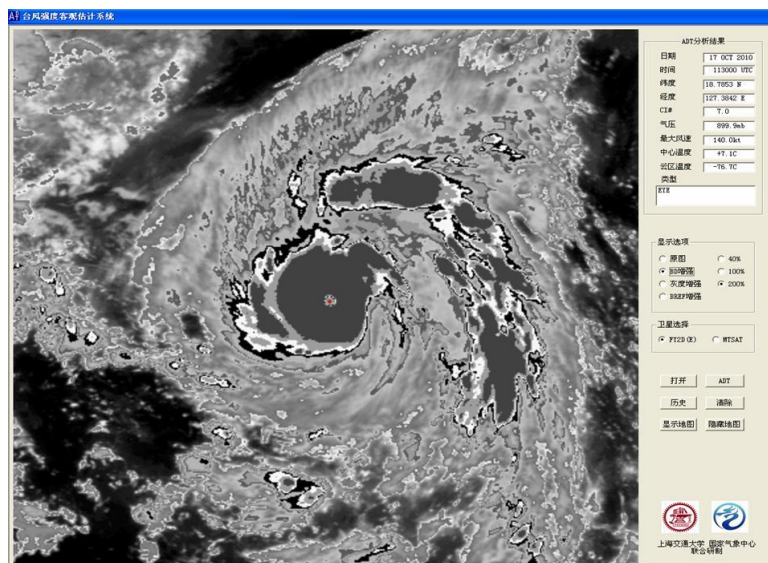

Fig. 5 An example from the Objective Typhoon Intensity Estimation System.

Outputs of both subjective and objective satellite analyses are 1-min averaged maximum sustained surface wind. As the national standard of surface wind observation in China is 2-min

mean, forecasters need to make some adjustment base on his/her experience and real time conditions.

2. POST SEASON SATELLITE ANALYSIS

Satellite analysis is an important component of post season best track analysis in CMA (Fig. 6).

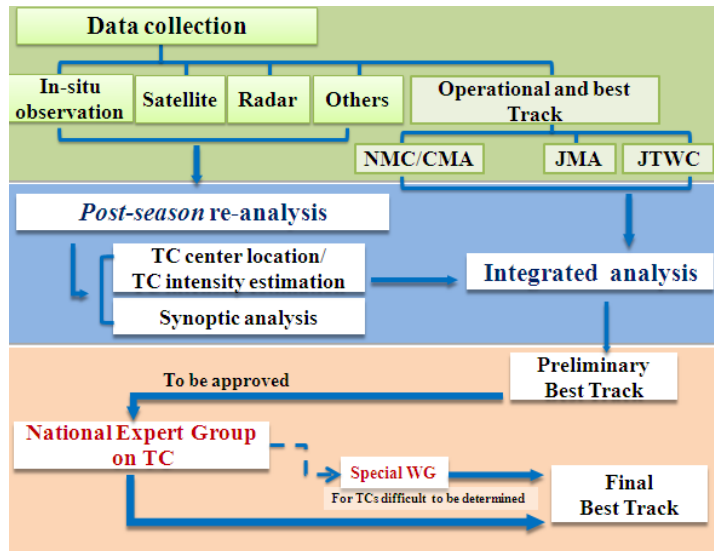

Fig. 6 Main procedures of post season best track analysis in CMA

Dvorak analysis is not performed specifically during the post season re-analysis process. Instead, the real time satellite analysis issued by NMC/CMA is served as an important reference.

As a supplement, a mathematical morphology-based algorithm (Liu et al. 2003) is applied on IR cloud image to help locating the center of a system without eye (Fig. 7).

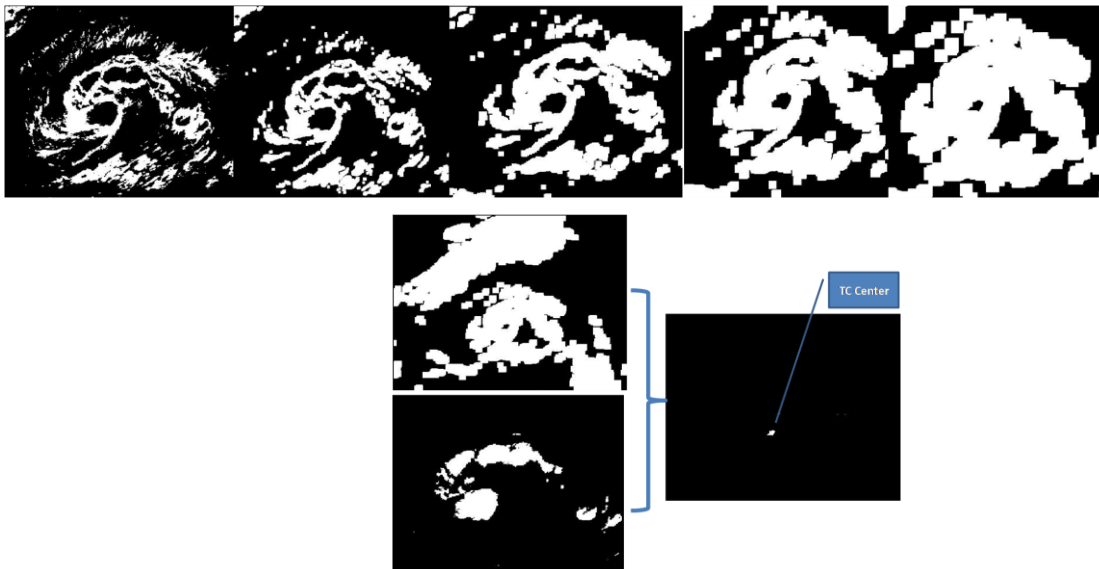

Fig. 7 An example of morphology-based TC positioning

An intensity estimation technique (Fan et al. 1996) similar to Dvorak analysis is applied on IR cloud images to provide supplementary reference for final intensity determination (Fig. 8). The technique places emphases on extracting factors describing the structure of cloud systems, including the tightness of clouds and the characteristics of spiral bands.

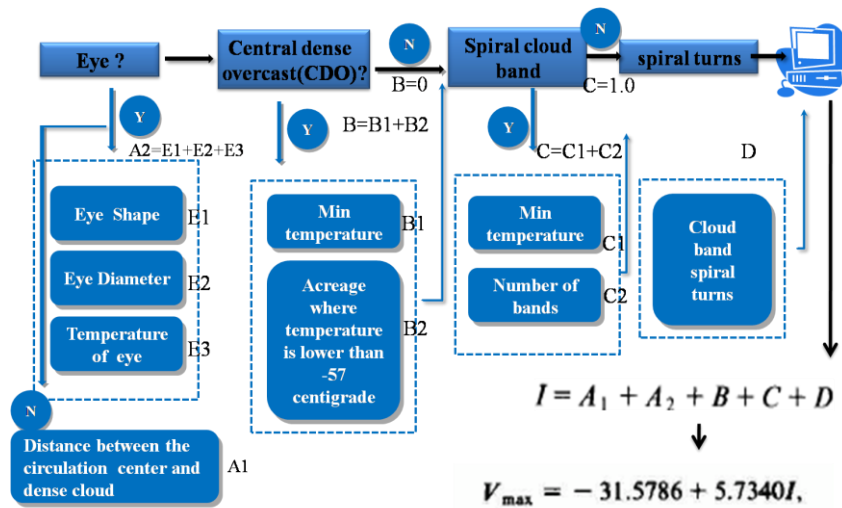

Fig. 8 Flow chart for the intensity estimation technique proposed by Fan et al. (1996)

An STI-in-house objective intensity estimation method is also applied to provide extra reference. The technique is based on statistical relationship between intensity and convective cores information, such as the core counts, distance to tropical cyclone center, minimum temperature, and so on.

Microwave images are used more and more frequently in post season satellite analysis. However, no canonical procedure has been set up for the application of these images.

REFERENCE:

- [1] FAN Huijun, LI Xiufang, YAN Fangjie et al. 1996: A Technique to Estimate the intensity of Tropical Cyclone Based on S-VISSR Data. Scientia Atmospherica Sinica. 20(4), 439-444
- [2] LIU Zhengguang, QIU Haiming, WU Bing et al. 2003: Center Locating of Non-Eye Typhoon Based on Satellite Cloud Image. Journal of Tianjin University, 2003(6), 668-672
- [3] LU Xiaoqin and Lei Xiaotu. 2005: To Improve the Objective Position Precision of TC with GIS. Journal of Applied Meteorological Science, 16(6), 841-848.

Annex GTS code of NMC/CMA real time satellite analysis

```
TCPQ40 BABJ IIIIII
CCAA IIIII 99398 11165
TC name ntnilalala 1lolololo 1AtWtatm 2StSt// 9dsdsfsfs=
```

BABJ is the code of forecast center (NMC/CMA)
 $n_t n_i$ is the number of TC
 lalala_i is latitude of TC center
 lolololo_i is longitude of TC center
 At is the accuracy of the location of TC center
 Wt is the averaged diameter of central dense overcast
 a_t is the change TC intensity within 24hours
 t_m is the interval of calculating TC
 StSt is the CI number
 dsds is the direction of TC movement
 fsfs is the speed of TC movement

OPERATIONAL PROCEDURES OF TC SATELLITE ANALYSIS AT HONG KONG OBSERVATORY

1. INTRODUCTION

The Hong Kong Observatory (HKO) has long been using manual Dvorak analysis (1984) on satellite imagery for operational estimation of the intensity of tropical cyclones (TCs). Once a potential TC is suspected to soon form, a Dvorak analysis will be performed as often as deemed appropriate for assessing the current intensity of the TC. For TCs within 0-36 N, 100-140 E, Dvorak analysis will be performed at least for 00, 06, 12 and 18 UTC imageries. For TCs within the HKO area of responsibility (viz. 10-30 N, 105-125 E), additional analysis will be performed for 03, 09, 15 and 21 UTC imageries. Operational position and intensity are provided in Hong Kong Tropical Cyclone Warning for Shipping and local tropical cyclone warnings for the public.

A post-season reanalysis of storms is carried out and the information is incorporated into the TC best track dataset. HKO's best track records started as early as 1884, but more complete records were kept since 1961. HKO produces best tracks for TCs within 0-45 N, 100-160 E until 1960 and 0-45 N, 100-180 E from 1961 onward. The maximum 10-minute surface mean wind and the minimum pressure of TCs are given in the best track dataset at 6-hourly intervals.

2. LOCAL VARIATIONS TO DVORAK (1984)

The Enhanced IR Dvorak technique has been in use operationally in HKO since early 1980s. Prior to that, the Dvorak analysis was initially carried out using the visible imageries. For reporting and warning purposes, a conversion factor of 0.9 was adopted in Hong Kong to convert 1-minute mean winds from the Dvorak wind table into 10-minute mean winds.

While there is no formal reference in the Dvorak technique about its application to TCs making landfall, Dvorak analysis is being applied in Hong Kong to TCs over the sea as well as over land.

Currently, no Dvorak analysis will be performed after a TC has transitioned into an extratropical low. Extratropical systems are not included in the HKO best tracks.

3. UNIFORMITY IN APPLICATION OF DVORAK TECHNIQUE

The HKO forecasters will carry out Dvorak analysis and fill in the tropical cyclone analysis worksheet as described in the appendix of Dvorak (1984) during operation but the information such as the current intensity (CI) or T-numbers are not being reported outside of HKO and digitized.

According to Step 9 in Dvorak (1984), the CI is to be held constant for 12 hours during the initial weakening of a TC. Normally, the HKO forecasters follow this weakening rule even when the TC has made landfall or is crossing large landmasses such as the Philippines. However, the forecasters may ignore this rule for landfalling TCs on a case-by-case basis and discussion is being made in HKO about whether to allow the final T-number to decrease once the centre of the TC hits land.

4. CHANGES IN PROCEDURES OVER TIME

There has been little change to the procedures over the years.

5. DETERMINATION OF TC FINAL INTENSITY

In determining the final intensity of a TC, surface wind and pressure reports are regarded as ground truth but the quality of the observations are also taken into account (for example, pressure reported by ships can sometimes be suspicious). For TCs over the ocean where such

observations are sparse, Dvorak analysis is used as the main tool for TC intensity determination. Other satellite intensity estimates, e.g. wind scatterometer, ADT, etc., are used as references.

Tropical cyclone's central pressure is estimated based on the surface pressure reported by land stations and ships, reconnaissance aircraft reports when available and Dvorak analysis via the wind-pressure conversion table.

The maximum surface mean wind speed is estimated based on the surface winds reported by land stations and ships, Doppler wind observations from radars, reconnaissance aircraft reports when available and Dvorak analysis. Estimates from wind scatterometer data, ADT, SATCON and the Multi-platform Tropical Cyclone Surface Wind Analysis by NOAA are also referenced.

6. INFLUENCES OF TECHNOLOGICAL ADVANCEMENTS ON DVORAK ANALYSIS

One notable influence is due to the advent of microwave imageries in recent years. Microwave imageries are less frequently available, but can serve as a supplement to Dvorak analysis. They enable the forecasters to see through clouds and view rainbands and eye of the TCs even when obscured by upper-level clouds, thereby helping to reveal the best pattern (e.g. banding versus shear or an eye pattern under a central cold cover) to use in the Dvorak classification. In addition, sea-level winds measured by QuikScat and ASCAT serve as a check on the location and strength of TCs.

7. ANCILLARY DATA CONSIDERED IN PRODUCING FINAL SATELLITE INTENSITY ESTIMATE

Since 2009, HKO has incorporated the "Advanced Dvorak Technique (ADT)" developed by the University of Wisconsin-Madison / Cooperative Institute for Meteorological Satellite Studies (CIMSS) as an objective reference tool for weather forecasters. ADT makes use of computer-based algorithms to objectively identify cloud pattern types, calculate the eye/convective cloud temperatures, apply selection rules, and derive intensity estimate for TC. One advantage of this tool is that it can be fully automated. The ADT is presently applied to the TC positions determined by the forecasters.

Scatterometer winds such as ASCAT or previously QuikScat, NOAA Multiplatform satellite surface wind analysis, images from microwave sensors available in the NRL website (<http://www.nrlmry.navy.mil/TC.html>), other resources from the web such as satellite-derived winds and dropwindsonde observations are also referenced by HKO forecasters.

8. PRESSURE WIND RELATIONSHIP IN USE

The empirical relationship between CI, the minimum sea level pressure (MSLP) for the Western North Pacific Basin and the 1-minute maximum mean wind speed (MWS) given in Dvorak (1984) is in operational use at HKO. A conversion factor of 0.9 is applied to convert the 1-minute mean winds to 10-minute mean winds. There have not been any changes regarding the above over the years, but HKO is currently considering adopting the new conversion factor of 0.93 as proposed in WMO/TD-No. 1555.

Conversion of the Dvorak CI number to MSLP and MWS

CI Number	MWS (10-minute mean in knots)	MSLP (hPa)
1.0	23	
1.5	23	
2.0	27	1000
2.5	31	997
3.0	41	991
3.5	49	984
4.0	59	976
4.5	69	966
5.0	81	954
5.5	92	941
6.0	103	927
6.5	114	914
7.0	126	898
7.5	139	879
8.0	153	858

9. SYSTEMS TO ENTER THE BEST TRACK RECORDS

Best tracking has been carried out by HKO officers who have rich experience in TC operation. The best tracks are determined independently from the operational environment. An advantage of best tracks over operational tracks is that the analyst can look back and forth to ensure a more reasonable and consistent track. References are also made to additional information such as tropical cyclone passage reports and best track data issued by RSMC Tokyo, which are not available operationally. Currently, there is no periodic re-visit of the best track record from previous years - this is only done on an ad-hoc and need-only basis.

The best track intensity will not normally differ too much from the warning intensity. Strong evidence is required for large changes in intensity.

DVORAK PROCESS IN JOINT TYPHOON WARNING CENTER

The Joint Typhoon Warning Center (JTWC) adheres to the following technical guidance when performing tropical cyclone analysis (positioning and intensity estimates):

- A Workbook on Tropical Clouds and Cloud Systems Observed in Satellite Imagery – Volume II – Tropical Cyclones, Dvorak, V. F. 1984 (NAVEDTRA 40971)
- Tropical Cyclone Intensity Analysis Using Satellite Data, Dvorak, V. F. (NOAA Technical Report NESDIS 11 – September 1984)
- The Dvorak Tropical Cyclone Intensity Estimate Technique, A Satellite-Based Method that Has Endured for over 30 years, Velden, et al, 2006 (BAMS, Vol 87 Issue 9, pp 1195 - 1210)
- Intensity Estimation of Tropical Cyclones During Extratropical Transition (JTWC/SATOPS/TN-97/002, Dennis Miller and Mark A. Lander, PhD, Apr 1997)
- A Satellite Classification Technique for Subtropical Cyclones, Herbert, P.J. & Poteat, K. O., 1975 (NOAA Technical Memorandum NWS SR-83 - 1975)

The following are local JTWC policies that are utilized with above guidance:

POLICY FOR PERFORMING DVORAK INTENSITY ESTIMATES OVER LAND

Satellite analysts will not perform Dvorak intensity estimates over large land masses such as Australia, China, India, Africa, and other mainland areas. These areas also include the larger islands in the area of responsibility, especially ones with mountainous topography, such as the Philippines, Taiwan, Mainland Japan, Sri Lanka, Madagascar, La Reunion, and the Hawaiian Islands.

The Dvorak intensity estimate should, however, be performed when possible. Performing a Dvorak intensity estimate over or near land will be a combined decision of the satellite analyst and the Typhoon Duty Officer (TDO) on duty. If the decision is to perform the estimate, then the following remark will be added to the remarks section of the Fix Entry Page. “Dvorak intensity may not be representative due to land influences.”

If the satellite analyst does not perform an intensity estimate append the following remark to the remarks section of the Fix Entry Page. “Intensity estimate not performed due to systems proximity to land.”

POLICY ON BREAKING CONSTRAINTS

While Dvorak constraints limit the amount of fix-to-fix variability due to rather short-lived fluctuations in system convection, it is sometimes necessary to break constraints to represent a rapidly developing or weakening trend. In this case, the analyst is encouraged to break constraints to provide the TDO and JTWC customers with the most accurate data possible. The analyst must provide sound reasoning for breaking constraints in the remarks section of the fix bulletin. The analyst must also consult with the TDO and contact Satellite Operations (SATOPS) leadership prior to deviating from the current Final-T by two T-numbers or more.

POLICY FOR UTILIZING SUBTROPICAL INTENSITY TECHNIQUE

- A. SATOPs will use the subtropical technique of Hebert and Poteat (1975) to estimate the intensity of invest areas exhibiting the characteristics of a subtropical cyclone.
- B. A subtropical cyclone is defined in the National Hurricane Operations Plan as “a non-frontal low pressure system that has characteristics of both tropical and extratropical cyclones. This system is typically an upper-level cold low with circulation extending to the surface layer and

Appendix C: Satellite Analysis Procedures in Operational Centers

maximum sustained winds generally occurring at a radius of about 100 miles or more from the center.” According to Hebert and Poteet, the subtropical cyclone can originate from a decaying frontal wave, east of an upper trough, or from a cold low (TUTT cell.)

- C. As defined by Hebert and Poteat, the criteria to classify a cyclone as “subtropical” include: main convection being located north and east of center position, cloud system size is at least 15 degrees latitude or more, and the convective cloud system should remain connected to other synoptic systems. The satellite analyst and TDO will collaborate to determine whether the system meets the aforementioned characteristics, and the system should be declared “SUBTROPICAL”.

Note: additional data such as AMSU temperature cross-sections should also be examined, if available. After the subtropical determination has been made, the analyst will utilize the subtropical technique. The analyst will continue disseminating “subtropical” fixes until the system becomes tropical or extratropical in nature. Again, the TDO and SATOPS should collaborate to determine if/when the system has transitioned. At this point, all intensity estimates should be based on the traditional Dvorak or extratropical techniques.

MONSOON DEPRESSIONS

Assign an initial intensity of T0.0 since the Dvorak technique does not handle these systems well. These fixes will be position only and will not be transmitted. These fixes are typically only used within JTWC.

JTWC will continue assigning an intensity of T0.0 until Dvorak patterns and rules apply.

DEVELOPMENT OF OBJECTIVE SATELLITE-BASED TROPICAL CYCLONE INTENSITY ESTIMATION TECHNIQUES

National Environmental Satellite, Data, and Information Service (NESDIS)

1. DVORAK TECHNIQUE

Much of the information contained in this section was provided by Andrew Burton, TCWC Perth.

1.1 Introduction

The Dvorak technique matured over an extended period and there is no single reference that wholly defines the application of the technique, (although the “Workbook on Tropical Cloud Systems...” published in the early 1990s, and available in SAB, is recommended as a training resource). This section tries to bring together a collection of notes regarding the application of the Dvorak technique as a reference for operational cyclone forecasters.

The limitations of the technique are covered, together with common traps for inexperienced analysts, ambiguities in the original texts and some possible modifications to the technique. Most of this material comes straight from the “standard” Dvorak publications. Some points are derived from later studies or represent a consensus amongst a number of experienced analysts. Priority is given to indications given by Dvorak and all points are referenced to at least one source.

1.2 General Comments

1. When available use VIS-IR pairs. Perform at least two VIS analyses per day to check agreement between VIS and IR analyses.¹²
2. **When an image can be analyzed using more than one pattern perform both analyses and compare the results.**¹³
3. **Always try to analyze more than one image leading up to the analysis time – then average the resulting DT numbers.**^{9,11} **This is particularly applicable to shear patterns** that often go through a cyclic pattern of convection blow-up near the low level center followed by increasing separation of the overcast from the low level center. This can lead to rapidly varying DT numbers over several hours.¹³
4. It is good practice to perform a reanalysis of earlier imagery whenever a TC reaches a stage of well-defined intensity (for example when an eye first appears). The dependency of the Dvorak technique on the MET can lead to situations where it appears that model constraints have to be broken, when in fact a reanalysis of previous days’ data shows that earlier FTs could have been higher and the analyst(s) has/have “got behind the power curve”.^{12,13}
5. Recognize the limitations of the Dvorak technique – it was not designed for monsoon depressions, sub-tropical systems or systems undergoing extra-tropical transition.^{12,13}
6. The Dvorak technique does not adjust for the effects of system translation on surface winds. It was initially derived using a set of cyclones with an average speed of around 3-12 knots.^{12,14} For systems with close to average translation speeds the error from this will generally be much less than that inherent in the technique itself. For systems with rapid translation speeds the error may be significant, however the effect of translation on surface wind speeds is complex and non-linear and there is no systematic way of incorporating these effects into warning policy. JTWC reportedly uses a rule-of-thumb involving adding an extra knot to the maximum surface wind for every knot of translation over 20 knots.¹²

7. There can be times in a TC's life cycle when no DT can be determined – **do not force a DT when no pattern can be applied – use the MET or other observations (eg. scatterometer data) to help estimate intensity in these circumstances.**^{12,13}
8. The winds experienced at the surface vary depending on the presence of deep convection. Thus a weak system that is going through a diurnal maximum in convection will generally have larger areas of more damaging winds than a weak system that is going through a diurnal minimum in convection. This can make the difference between a Category 2 (Australian scale) impact and a Category 1 or weaker impact.¹³
9. Midget cyclones (gale radius < 60nm) present problems for analysis.¹² Although Dvorak states “It is the pattern formed by the clouds of a tropical cyclone that is related to the cyclone's intensity and not the amount of clouds in the pattern”⁹, several parts of the technique rely on measurements of size (most noticeably in the CDO pattern, but also when determining BFs). Midget storms tend to intensify and decay more rapidly than larger storms.¹²
10. Whenever Dvorak talks about the “model” he is referring to the Dvorak model of TC development wherein a cyclone intensifies by one T-number per day.
11. It is a common mistake amongst inexperienced analysts to assume that the MET is the same as the “Forecast Intensity Number” from 24 hours ago. **The first step in determining the MET is to qualitatively compare images 24 hours apart (remove diurnal influences) and decide whether the storm has Deepened (D), Weakened (W) or remained Steady (S). The second step is to add or subtract between 0 and 1.5 from the 24 hour old FT (not the DT or CI) based on the D,S,W determination.**^{9,11}
12. The Pattern T-No (PT) is not independent of the MET – it is an adjustment to the MET.⁹ **The PT is determined by first establishing the MET, then determining whether the pattern in the current imagery looks “obviously stronger or weaker”⁹ than the corresponding pattern indicated at step 6 on the flow chart. The MET can then be adjusted by ± 0.5 (no greater adjustment can be made¹¹) and the resulting T-No is called the PT (we could have called it the “adjusted-MET”).**
13. Sometimes the Dvorak technique, with its adjustments, will indicate that a tropical cyclone with a ragged eye is only at T3.5. A reasonable rule-of-thumb is that if an eye is clearly discernible, then regardless of how ragged it is the storm is at a minimum of T4.0.¹²
14. The rules for determining the FT imply that **“the more vague or conflicting the evidence of intensity, the more the estimate should be biased toward the MET”.**¹¹ **Even where the DT measurement is clear cut, the FT must be within ± 1.0 of the MET.**^{1,9,11}
15. The advent of frequent passive microwave imagery has given tropical cyclone forecasters greater insight into structural and intensity changes in tropical cyclones than can be obtained through IR and VIS imagery alone. The Dvorak technique cannot be validly applied to microwave imagery, however forecasters should use microwave imagery to assist in determining the centre position. Trends in intensity that are evident in sequences of microwave imagery can also inform the analysis process.

1.3 Curved Band Patterns

1. Note the modeled cloud system center (CSC) positions in flow diagrams – do not centre the spiral at the CSC in early stages of development.¹³
2. It follows from (1) that intensity analysis is not critically dependent on accuracy of center location. However **the CSC should always lie within the curvature of the band.**^{1,9}
3. Deciding where a band stops and starts is critical to the success of the method. **The band does not have to be continuous – you should draw your band axis through small breaks** (Figure 1-1).⁸ Conversely you should **beware of continuing to draw a curved**

band axis at the outer limit of the band when there is no remaining curvature (Figure 1-2). (This is usually only a problem in IR imagery where the cirrus outflow can appear to be a continuation of a deep convective band) .¹³

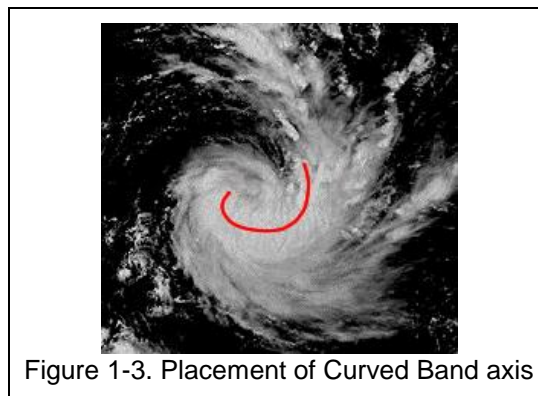
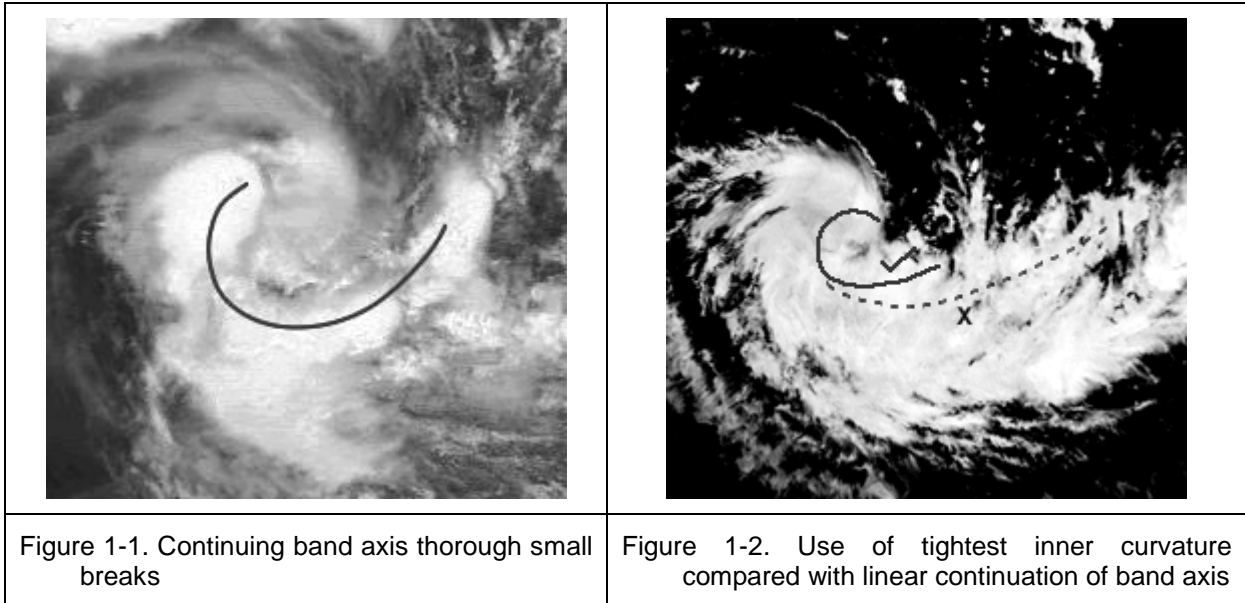

4. Try to place your band axis parallel to the cold, dense overcast edge nearest the cloud minimum wedge (concave side).¹¹ **Ideally the axis will be situated one-third into the cloud band from the concave side** (Figure 1-3).
5. The expected center position is halfway between the end of the curved band (A) and the end of the associated dry slot or cloud minimum wedge (B) (Figure 1-4).

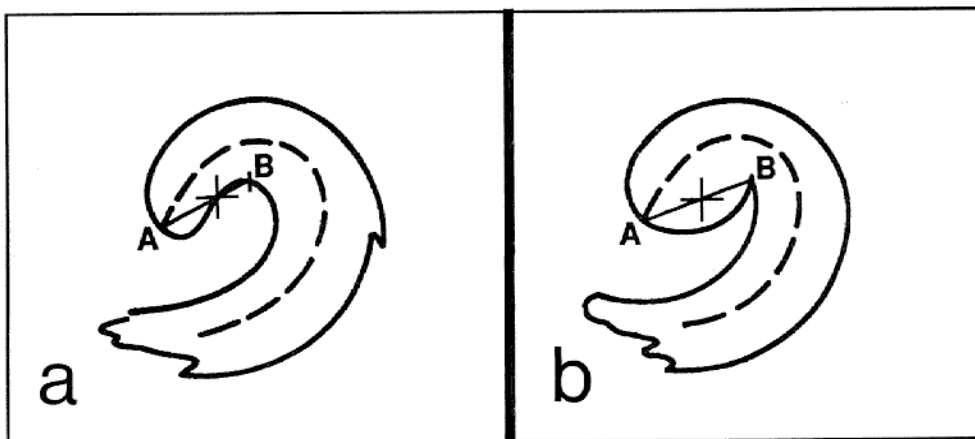
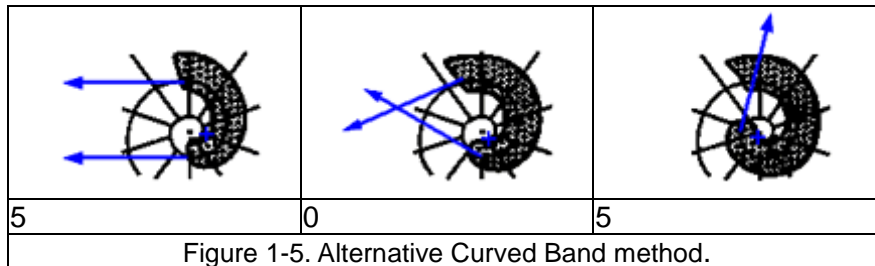

Figure 1-4 showing the expected cloud system center for curved band patterns.

6. Experienced analysts are often able to visually estimate the degree of curvature without counting the tenths of a spiral. Some have developed simple rules and find them a useful adjunct to the “count the tenths” method. For example, consider the figure below covering the Curved Band pattern over the critical range DT2.5 to DT3.5. We can see that if the $DT < 3$ then linear extensions of the band axes will never intersect. (In fact if the band wrap is 0.55 they will eventually intersect but the precision is sufficient for our purposes). If the $DT = 3$ then the linear extensions of the band axes will intersect. If the $DT > 3$ then the linear extension of the band axis at the “head” the band will intersect the band itself.¹³



7. The log10 spiral does not have a physical basis – it was an empirical choice, other spirals, or a circle, can be used.⁸ **So don't get hung up on fitting your band axis to the spiral exactly.**
8. **Always go for the band with the tightest inner curvature – this may not be the largest, most noticeable band** (Figure 1-2).¹³
9. The degree of incursion of the “cloud minimum wedge” is also an indication of the intensity of the storm (a corollary to the degree of wrap of the band itself).¹³

1.4 Eye Patterns

1. The VIS eye technique is not as objective as the EIR technique for intensity estimates.^{4,9,11} The EIR technique is also considered to be more “reliable.”¹³ **“The EIR technique should be used instead of the VIS whenever possible for cyclones of hurricane intensity”.**¹¹
2. Eye size – there is some slightly conflicting information regarding the delineation between “small” and “large” eyes, particularly with respect to the eye adjustment factor (Table 1.1). When determining the E (eye) number in a VIS Eye pattern analysis, a small eye is one $< 30\text{nm}$ – this is consistently defined in the various Dvorak publications. However when determining the eye adjustment factor the pre-1982 literature defines a large eye as $\geq 0.75^\circ$ ($\geq 45\text{nm}$) for VIS imagery and $\geq 0.6^\circ$ ($> 36\text{nm}$) for EIR, while the publications in 1982⁸ and 1984⁹ refer to large eyes in EIR imagery as being $\geq 0.75^\circ$ ($\geq 45\text{nm}$) and does not explicitly define large eyes in VIS. From this information we can at least say that **an eye with diameter $< 30\text{nm}$ is small for all purposes (E and E_{adj}), and an eye with diameter $\geq 45\text{nm}$ is large for all purposes.** In between there is some ambiguity, but given the overall precision of the technique it is not a large concern. If this ambiguity leads to an uncertainty of 0.5 in the DT then once again the analyst should be guided by the MET. Dvorak indicated that if the eye is not circular in visible imagery, use the longest diameter when determining eye size. For the sake of consistency and simplicity, the same logic will be applied to EIR imagery even though there is no explicit mention of this in any of Dvorak's publications [personal communication with A. Burton dated 2/14/2011].

Table 1.1. Definition of Large Eyes for E_{adj}		
Publication	VIS Definition	EIR Definition
Feb 1973	$\geq 0.75^\circ$ ($\geq 45\text{nm}$)	N/A
1978 - 1980	$\geq 0.75^\circ$ ($\geq 45\text{nm}$)	$\geq 0.6^\circ$ ($> 36\text{nm}$)
1982-1984	Not explicitly defined under E_{adj}	$\geq 0.75^\circ$ ($\geq 45\text{nm}$)

$$\text{EIR} = [E + \text{eye adj} + (\text{BF adj}) = \text{DT}]$$

3. In the EIR technique BF additions are only made when the DT would otherwise be less than the MET.^{9,11}

The BF addition is used with EIR pictures only when

- (1) the CF is 4 or more
- (2) the T-number estimate without the BF is lower than the model expected T-number
- (3) the system contains a clear-cut comma tail band that
- (4) curves 1/4 or more of the distance around the central features or comma head,
- (5) is cold (MG or colder), and
- (6) has a warm edge (DG or warmer) between the tail and the central features that cuts at least halfway through the pattern for patterns a and b, Figure 1-6, and at least 2/3 the way for pattern c.

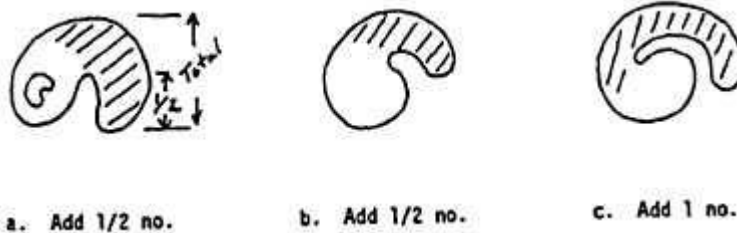

Figure 1-6 showing EIR banding features. Add to the CF only when the DT is lower than the MET.

Example of Insufficient Warm Edge (DG and warmer)

In the image in Figure 1-7 below, no banding feature can be added because the warm edge between the tail and central features, although cutting half way through, is not sufficiently warm (DG or warmer).

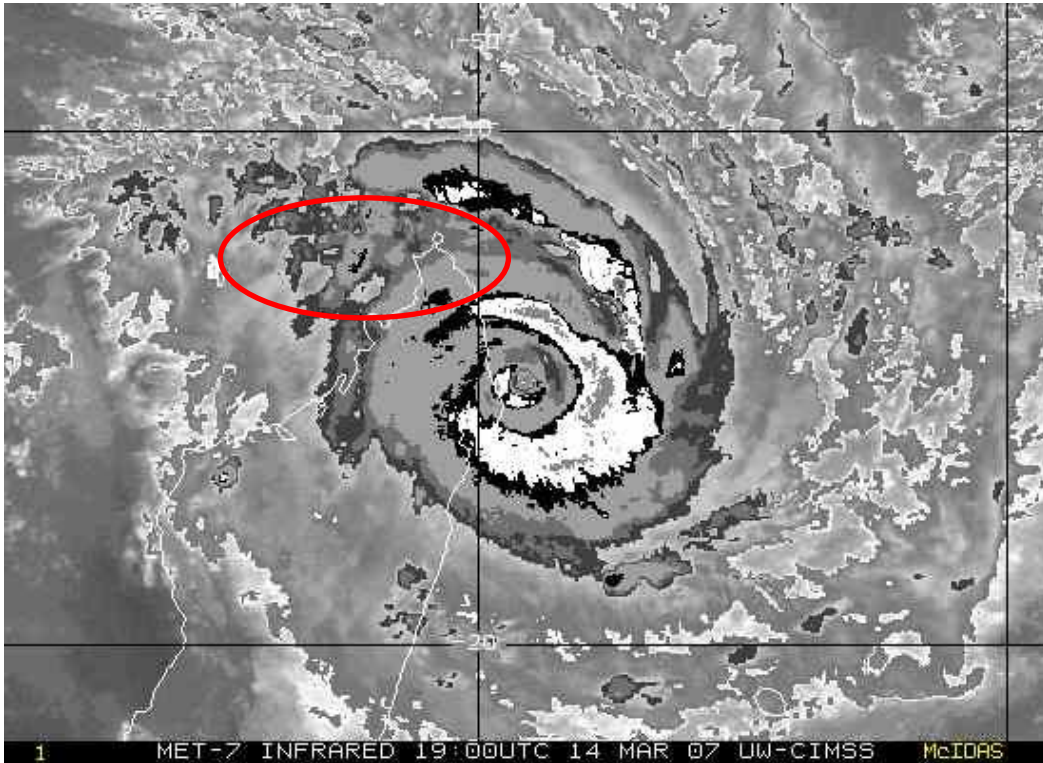

Figure 1-7 showing an example of insufficient warm edge (enclosed in an oval) associated with a banding feature.

Example of Sufficient Warm Edge (DG and warmer)

Three hours later, however, a DG warm edge cuts more than half way through (Figure 1-8) and a banding feature could be added provided all other criteria are met.

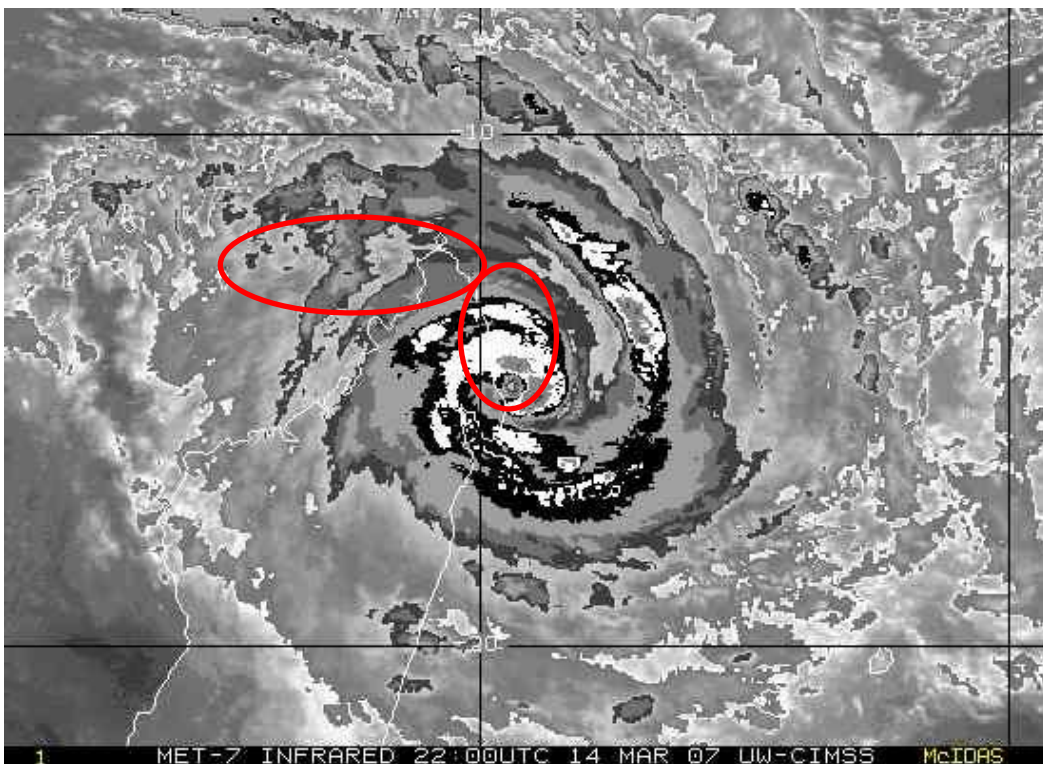

Figure 1-8 showing an example of a sufficient warm edge, the entirety of which is encompassed within two ovals, associated with a banding feature.

Appendix C: Satellite Analysis Procedures in Operational Centers

4. Do not use the VIS Banding Feature Additions diagram on the flow chart for EIR imagery – that diagram is intended for VIS imagery only.⁹ Refer to Dvorak (1982b, 1984) for the EIR Banding Feature diagram.
5. **There is no minimum width criteria when determining the surrounding ring temperature for the Eye Adjustment Factor (E_{adj}) (Table 1-2).**¹¹

		EYE TEMPERATURE							
		WMG	OW	DG	MG	LG	B	W	CMG
TEMPERATURE	OW	0	-0.5						
AROUND	DG	0	0	-0.5					
THE	MG	0	0	-0.5	-0.5				
EYE	LG	+0.5	0	0	-0.5	-0.5			
	B	+1.0	+0.5	0	0	-0.5	-0.5		
	W	+1.0	+0.5	+0.5	0	0	-1.0	-1.0	
	CMG	+1.0	+0.5	+0.5	0	0	-0.5	-1.0	-1.0
	*CDG	+1.0	+0.5	+0.5	+0.5	0	0	-0.5	-1.0

Table 1-2 showing the table of eye adjustments where CDG ring is extrapolated from Dvorak (1984).

6. When determining the E (eye) number for a spiral eye, use the average width of the spiral band to determine the minimum width criteria.⁹
7. **No “plus” Eye Adjustment should be made for large eyes ($\geq 0.75^\circ$ ($\geq 45\text{nm}$) diameter within surrounding grey shade) or elongated eyes (short axis $< 2/3$ the long axis).**⁹

The expression “**within the surrounding grey shade**” is very important. Assuming a WMG eye, there is no **positive adjustment** for the eye **ONLY** if the WMG has a diameter of at least of 0.75° . This makes all the difference! Many forecasters believe that the measurement is made without the BD curve applied (e.g., with the black and white picture) and very often, this leads to a big mistake: the measurement is made at the top of the eye which is very often larger than the bottom (e.g., the area covered by WMG in our example).

8. **For elongated eyes: if no previous subtraction has been made, subtract 0.5 for E (eye) numbers ≥ 4.5 .**⁹

$$\text{VIS} \quad [E + E_{adj} + \text{BF adj} = \text{DT}]$$

9. **Embedded distance is measured from the center of the eye for small eyes ($< 30\text{nm}$ diameter), otherwise from the inner wall of the eye.**^{9,11}
10. **When determining eye size, if the eye is not circular use the longest diameter.**³
11. Large eye sizes are defined differently for E and E_{adj} (see general comments on eye patterns)
12. Eye adjustment factor (E_{adj}) is determined by:^{9,11}
 - Definition – poorly defined=barely visible, well defined=dark
 - Shape – ragged eye=very uneven boundary, little circularity
 - Size – large is $\geq 45\text{nm}$ (?)

13. When an adjustment is not clear-cut, use the guidance of the MET to make final decision.⁹
14. **The BF is always considered for VIS imagery, not only when $DT < MET$ as with EIR patterns.**^{9,11}
15. **The VIS eye technique is not as objective as the EIR technique. The EIR technique is also considered to be more “reliable”. When there is conflict between the DTs determined by the two methods weight towards the EIR technique.**¹³

1.5 Shear Patterns

1. Works best with VIS imagery where the boundary of the dense overcast is better defined.¹³
2. The Dvorak flow chart suggests the use of DG to define the overcast in IR imagery, however this often does not correspond with the boundary of the overcast suggested by the VIS imagery. **When performing a shear analysis overnight (ie. without VIS imagery), consider looking for the strongest gradient in temperature to define the overcast boundary, rather than sticking to the DG shade.**¹³
3. Shear pattern intensity estimates are not determined solely on the distance from the low level center to the overcast – they also depend on the definition of the low level center. **To achieve a $DT \geq 2.5$ requires that the low level center be defined by parallel, circularly curved low cloud lines near or under an overcast with a diameter $\geq 1\frac{1}{2}$ degrees latitude.**^{5,9}
4. In a later publication¹¹ the shear diagram was modified to allow greater freedom in the assignment of the DT. The previous schematic for $DT=2.5$ was labeled as $DT3 \pm 0.5$, and the previous schematics for $DT=3.0$ and 3.5 were not shown. This may indicate an acknowledgement of the difficulty of using shear patterns given that the distance between the LLCC and the deep convection tends to vary significantly over a period of a few hours under a shear regime. However most Tropical Cyclone Warning Centres still use the older flow diagrams.
5. Dry air entrainment can present similarly to the shear pattern. To ascertain dry air entrainment, analyze precipitable water (PW) from microwave sensors by typing:

```
BATCH [[lat]][[lon]][[mag]] LOPPW           24hr/3 frame SSMI PW loop
BATCH [[lat]][[lon]][[mag]] AMSULOOPW      36hr/6 frame AMSU (NSC) PW loop
BATCH [[lat]][[lon]][[mag]] BLTPW 36hr/6 frame Blended TPW loop
```

1.6 CDO Patterns[CF + BF = DT]

1. Designed for use only with VIS imagery.^{7,9}
2. Intensity measurement not dependent on center location.^{7,9}
3. **Can often do a curved band analysis on these images by drawing the axis of the band through the CDO – try both and compare results.**^{11,13}
4. Size matters – CF is determined by size (and definition) of overcast, this has implications for analysis of midget cyclones (see general comments)¹²

1.7 Embedded Center Patterns

1. Intensity estimate dependent on center location – but accuracy of center location is often poor (by definition LLCC is covered by overcast).^{7,9} Often works best when an eye has just disappeared (and so there is relatively high confidence in the center location).¹³
2. Susceptible to abuse – remember that **embedded center patterns should only be applied when the 12-hour-old FT was ≥ 3.5 .**⁹ Application of the Embedded Centre pattern type will always yield a $DT \geq 3.5$ so it must be applied appropriately.

3. Dvorak says, **“Use the DT for the FT when the cloud features are “clear cut”.**^{7,9} Dvorak also indicates that **“the more vague or conflicting the evidence of intensity, the more the estimate should be biased toward the MET”**¹¹ **There is nothing clear cut about the cloud features in an embedded centre pattern,** and there is an implied vagueness about this intensity estimate because the center location is generally imprecise, **so you will often want to weight the FT towards the MET for these pattern types.**¹³
4. A number of experienced Southern Hemisphere analysts have noted that the temperature ranges used in the embedded center technique often appear to give higher than warranted DT numbers (often resulting in a discontinuous jump in the DT when the embedded center pattern is used after using some other pattern). Some analysts have postulated that this may be the result of the fact that TCs tend to occur on average at lower latitudes in the Southern Hemisphere compared with the northern hemisphere where the technique was developed. At lower latitudes the tropopause is higher and thus we would expect to see colder cloud top temperatures. Unfortunately there is insufficient data on which to assess these claims or to systematically correct this part of the technique. Analysts are therefore advised to note this perception based on experience and be prepared to weight towards the MET when determining the FT. (Based on personal communication of the author with a number of experienced analysts.)

1.8 Central Cold Cover Patterns

1. This is not a pattern in the same sense as other pattern types – **you cannot derive a DT** – this is obvious from the Analysis Worksheet. Instead, this pattern is an indicator of “arrested development” – and has immediate implications for the FT and the ongoing rate of development.⁹
2. **This concept applies primarily to IR imagery** because with VIS imagery the CDO or curved bands are usually visible beneath the thin cirrus shield.^{9,11}
3. Important not to confuse very cold comma patterns with CCC – the former should have some indication of a cloud minimum wedge between comma head and tail.⁹
4. **There is also potential for confusion between Embedded Centre patterns and CCCs – use this part of the technique with caution, but do not ignore it.**¹³

1.9 References

1. Dvorak V.F. February 1973 “A Technique for the Analysis and Forecasting of Tropical Cyclone Intensities From Satellite Pictures”, NOAA Technical Memorandum NESS 45
2. Dvorak V.F. 1975 “Tropical Cyclone Intensity Analysis and Forecasting From Satellite Imagery”, Mon. Wea. Rev.,103(5),420-430
3. Dvorak V.F.(?) May 1978 Classification Procedures (Not sure of author – no attribution on source document – but appears to be written by Dvorak and a 1978 paper is referred to in the title of the 1979 publication below)
4. Dvorak V.F. November 1979 Tropical Cyclone Intensity Analysis Using Enhanced Infrared or VIS Imagery (A Revision of the 1978 method)
5. Dvorak V.F. September 1980 “Tropical Cyclone Intensity Analysis Using Satellite Enhanced Infrared or Visible Imagery – Training Notes”
6. West S. Nov 1980 Dvorak Technique, General Notes and Advice, not published, circulated internally to BoM
7. Dvorak V.F. May 1982a “Tropical Cyclone Intensity Analysis and Forecasting from Satellite Visible or Infrared Imagery – Training Notes”

Appendix C: Satellite Analysis Procedures in Operational Centers

8. Dvorak V.F. May 1982b “Appendix to Training Notes – A Technique for Tropical Cyclone Intensity Analysis and Forecasting from Satellite Visible or Enhanced Infrared Imagery
9. Dvorak V.F. September 1984 Tropical Cyclone Intensity Analysis Using Satellite Data, NOAA Technical Report NESDIS 11
10. Jiang Jixi and Dvorak V.F May 1987 Tropical Cyclone Center Locations from Enhanced Infrared Satellite Imagery, NOAA Technical Memorandum NESDIS 18
11. Dvorak V.F. 1992? 1993? 1994? A Workbook On Tropical Cloud Systems Observed in Satellite Imagery: Volume 2, Tropical Cyclones, (produced under NOAA/NESDIS/NWS Contract)
12. Guard Chip (pre1996) Applying the Dvorak Technique – notes provided to Fiji Met Service
13. West S 2002 Comments on the Dvorak Technique (not published – internal to BoM)
14. Brown D.P. and Franklin J.L. Dvorak Tropical Cyclone Wind Speed Biases Determined From Reconnaissance-Based “Best Track” Data (1997-2003), Proceedings of the 26th AMS Conference on Hurricanes and Tropical Meteorology Miami May 2004.

Acronyms

BF	Banding Feature
BoM	Australian Bureau of Meteorology
CDO	Central Dense Overcast
CF	Central Feature
CI	Current Intensity Number
CCC	Central Cold Cover
CSC	Cloud System Centre
DT	Data T Number
E	Eye number
E_{adj}	Eye adjustment factor
EC	Embedded Centre
EIR	Enhanced Infrared
FT	Final T-Number
IR	Infrared band satellite imagery
JTWC	Joint Typhoon Warning Centre (Honolulu)
LLCC	Low Level Circulation centre
LLCL	Low Level Cloud Lines
MET	Model Expected T Number
PT	Pattern T-No
TC	Tropical Cyclone
TCWC	Tropical Cyclone Warning Centre
VIS	Visible band satellite imagery

1.10 Rules Governing T-Numbers

1.10.1 The T1.0 Classification

A T1.0/1.0 classification can be given when:

- A convective cluster has persisted for 12 hr or more
- The cluster has a cloud system center (CSC) defined within a 2.5° latitude wide or less area which has persisted for 6 hr
- Associated convection is dark gray (DG) or colder on the Dvorak BD enhancement curve over an area $>1.5^\circ$ diameter less than 2° from the center

An existing CSC that does not meet the criteria above can be tracked as a system “too weak to classify” - a location without an intensity estimate. SAB will not position TWTCs in the Eastern and Southern Hemispheres, but may provide TWTCs in the Atlantic and East Pacific oceans during development when there is an active invest on the Naval Research Laboratory (NRL) web page.

1.10.2 Basis for the FT

FT should be based on (in order of priority):

1. the DT when it is clear cut (e.g., eye in EIR) else
2. the PT when PT is different from the MET else
3. the MET (e.g., EMB, SHR in EIR)

The rules for determining the FT imply that “the more vague or conflicting the evidence of intensity, the more the estimate should be biased toward the MET.”

Even where the DT measurement is clear cut, **the FT must be within +/- 1.0 of the MET.**

1.10.3 Rules Governing Changes to the FT

Maximum allowable change of FT for developing storms above T1.5 and 24 hours or more after the initial T1.0 (Lushine, 1977):

- 1.0 in 6 hrs
- 1.5 in 12 hrs
- 2.0 in 18 hrs
- 2.5 in 24 hrs

AND FT must be within +/- 1.0 of MET

Unless absolutely certain, it is best to use traditional rules of intensity change for developing tropical depressions and tropical storms (i.e., 0.5 in 6 hrs; 1.0 in 12 hrs, etc...).

The CI never constrains the FT!

Managing Extreme Intensification Rates

See Section 2.10.5 for guidelines on when to break the rules governing changes in the FT.

Managing Land Interaction

Appendix C: Satellite Analysis Procedures in Operational Centers

The Dvorak technique is not applicable over land and there are no hard and fast guidelines for what to do upon emergence back over water. The FT and CI may be set to the DT when a system has spent a considerable amount of time over land or even shorter times over very mountainous terrain (Haiti, Taiwan, etc.). Think of it as starting from scratch, but without any limitation on the FT/CI. In such cases the MET will be undefined and the analyst is released from the constraint limiting the FT to +/- 1.0 of the MET. The PT may be adjusted around the DT or left blank like the MET. Trust your instincts...or rather, go with your gut T!

Why are there constraints?

- Weak systems sometimes lose all convection during the diurnal minimum
- Cloud patterns for weak systems sometimes look unrealistically strong
- Strong systems sometimes don't intensify as quickly as the cloud pattern suggests
- In weakening systems, the decay of winds and pressures usually somewhat lags behind that of the cloud pattern

The issue of constraints can be quite controversial as some tropical cyclones clearly violate the Dvorak development constraints. Consider the example of Hurricane Wilma (2005) (Figure 1-9).

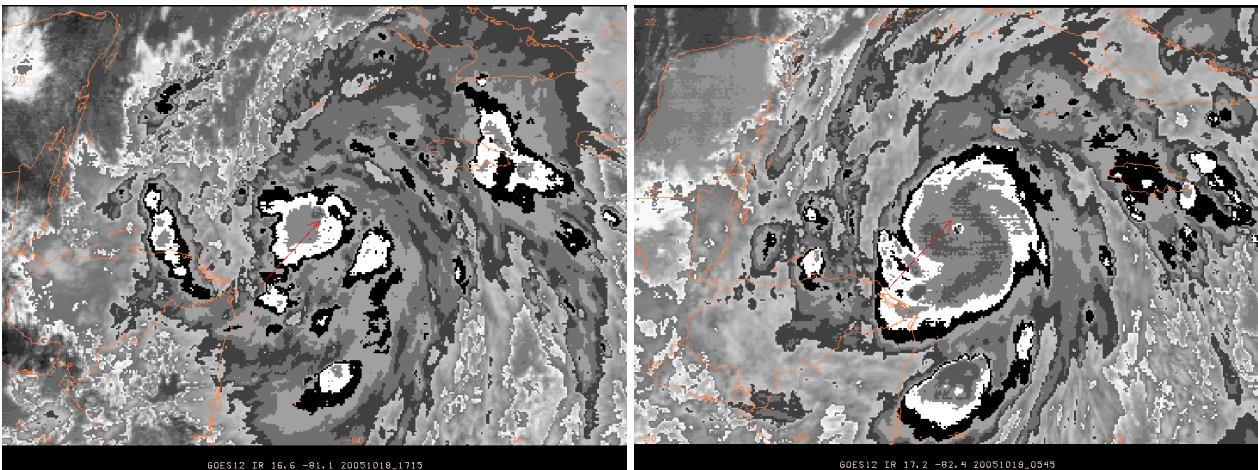

Figure 1-9 showing Hurricane Wilma at 75 knots and 975 mb (on left) and approximately 12 hours later at 150 knots and 892 mb (on right).

The example of Hurricane Wilma shows that extreme changes of intensity occur and so the rules governing the FT may need to be broken. To break the rules:

- Determine a DT once every hour since the last classification, including the classification time (or, for rapid development only, use ADT **RAW** T-no output on CIMSS page);
- Calculate the average DT over this period;
- You may use this average DT as the basis for FT even if it breaks any or all of the rules.

1.10.4 Rules Governing Changes in CI Number

- CI = FT except when FT shows a change to a weakening trend, or when redevelopment is indicated
- For weakening systems, hold the CI to the highest FT during the preceding 12 hr period, but never more than 1.0 above the current FT
- CI is never < FT!

Appendix C: Satellite Analysis Procedures in Operational Centers

- CI never constrains the FT!

See Table 1-3 for examples of changes in CI number at 6 hour intervals in cases of steady rapid development; accelerated weakening; interrupted weakening; and weakening then redevelopment.

Managing Extreme Intensification Rates

See Section 1.10.5 for guidelines on when to break the rules governing changes in CI Number.

CI Examples (6 hr Intervals)			
<u>FT/CI</u>	<u>FT/CI</u>	<u>FT/CI</u>	<u>FT/CI</u>
1.5/1.5	6.0/6.0	6.0/6.0	5.5/5.5
2.0/2.0	5.5/6.0	5.0/6.0	5.0/5.5
2.5/2.5	4.5/5.5	4.5/5.5	4.5/5.5
3.0/3.0	4.0/5.0	4.5/5.0	3.5/4.5
3.5/3.5	3.5/4.5	4.5/4.5	4.0/4.5
4.0/4.0	3.0/4.0	4.0/4.5	4.5/4.5
4.5/4.5	2.0/3.0	3.5/4.5	5.0/5.0
Steady Rapid Development	Accelerated Weakening	Interrupted Weakening	Weakening then Redevelopment

Table 1-3 showing examples of changes in CI number at 6 hour intervals in cases of steady rapid development; accelerated weakening; interrupted weakening; and weakening followed by redevelopment.

1.10.5 Managing Extreme Intensification Rates

Extreme intensification rates pose problems for Dvorak. When is it okay to break the rules? What rules may be broken?

First of all...It is good practice to perform a reanalysis of earlier imagery whenever a TC reaches a stage of well-defined intensity (for example, when an eye first appears). The dependency of the Dvorak technique on the MET can lead to situations where it appears that model constraints have to be broken, when in fact a reanalysis of previous days' data shows that earlier FTs could have been higher and the analyst(s) has/have "gotten behind the power curve".

What? The rules that may be broken are those governing changes in FT over 6-, 12-, 18- and 24-hour periods and, necessarily, the rule stating that the FT must be within 1 T of the MET.

When? Rules governing changes in T-numbers over time should be broken when the average DT calculated once each hour for a 6 hour period ending at the classification time is in excess of the constraints governing changes in the FT over time. The reasoning here is that we assume that the decrease in pressure and increase in wind speed follows the improved appearance in the imagery.

If the ADT (see Section 4.3.2.2) is successfully resolving the eye over the 6 hour period between classifications, you can simply average the initial raw T taken from the ADT output (e.g., column heading of Ini Raw). If the ADT has not resolved the eye, then the DT should be calculated manually once an hour over the 6 hour period ending at the classification time. The average value calculated by either method should be used as the subjective DT and the basis for the FT even if it exceeds all constraints.

Breaking the rules in this manner will aid future classifications since it results in more realistic values of the MET and PT in the future than could be achieved if rules were not broken. Speaking of which...the PT is by definition +/- 0.5 T-number of the MET. In deriving the PT you are merely asking yourself 'Does the image that appears on the screen right now look obviously stronger or obviously weaker than the pattern portrayed in the Dvorak flow chart for the MET.' Note that the PT is not merely searching the PT diagrams for that one that most closely resembles what is seen on the screen. Obviously, in the case of extreme intensification, the current satellite imagery will appear significantly better than the pattern suggested by the MET.

One may protest that it doesn't make sense to state that the MET is 5.0 and the PT is 5.5 when the DT suggests the system is a T7.5/7.5. However, there is added value to doing so, for when the FT is 2.5 T-numbers higher than the MET it sends a striking message to the user that something rather remarkable is occurring! Therefore, indicate what the MET and PT are as derived according to Dvorak's rules, but state in the remarks that these values are "not representative" and "constraints were broken."

1.11 Monsoon Depressions and the Dvorak Technique

Dvorak cannot accurately depict intensity in monsoon systems.

- Dvorak was designed to identify TC intensity based on a convective pattern around the central features of the TC
- It has a hard time describing pre-existing background winds (as in a monsoon)
- It has a hard time describing winds under convection that develop in the periphery of the center (again, as in a monsoon-like system)
- Similar problems exist when using Dvorak in subtropical TCs

2. SUBTROPICAL CYCLONES AND EXTRATROPICAL TRANSITION

2.1 Subtropical Cyclones

The Hebert-Poteat (HP) Technique is used to classify subtropical cyclones. Distinguishing between a tropical and a subtropical system can be very subjective. The following guidelines for determining the type of cyclone were taken from Hebert and Poteat (1975).

2.1.1 Differences between HP and Dvorak

CHARACTERISTIC	SUBTROPICAL	TROPICAL
Main Convection	Poleward & eastward from center	Equatorward & eastward from center
Cloud system size	Width 15° latitude or more	Width usually less than 10° latitude

Appendix C: Satellite Analysis Procedures in Operational Centers

Interaction with environment	Convective cloud system remains connected to other synoptic systems (some cold lows excepted)	Cloud system becomes isolated
------------------------------	---	-------------------------------

- HP permits a classification of ST1.5 or ST2.5 on the first day.
- HP cannot have a cloud system center (CSC) underneath a CDO.
- HP uses curvature of convective features for all ST classifications in the absence of bands.
- HP designates a wind speed range for each ST category.
- As applied in SAB, HP simply consists of an ST number; there is no FT/CI coding.

Dvorak	HP
T2.5/2.5/D1.0/24hrs	ST2.5
T2.5/3.5/W1.0/12hrs	ST2.5

2.1.2 Similarities between HP and Dvorak

- Both use the distance of the CSC from the overcast.
- ST cloud features are selected so that ST numbers correspond to T numbers if the cyclone becomes tropical.

2.1.3 Applying the HP Technique

The Tropical Pocket Guide, in a black binder located on one of the shelves above the Tropical Workstation, contains not only schematics of ST number patterns but examples as well. The Hebert-Poteat Technique uses the following guidelines in estimating the intensity of subtropical cyclones.

1. ST 1.5 (25-30 knots)
 - A. Low level circulation center $\Rightarrow 0.5^\circ \leq 2^\circ$ latitude from poorly organized convection (not necessarily dense)
 - B. For cold lows convection may not be connected to other systems and a small area ($< 3^\circ$ latitude) of deep layer convection exists near the center.
2. ST 2.5 (35-40 knots)
 - A. Low level circulation center $\Rightarrow 0.5^\circ \leq 2^\circ$ latitude from increased deep layer convection with greater curvature than previous day (not necessarily dense).
 - B. Outer convective band $5^\circ-10^\circ$ of latitude east of the center and possibly another convective band $2^\circ-4^\circ$ west-north of center.
3. ST 3.0 (45-50 knots)
 - A. Same criteria as 2 above except greater curvature and better organized convection than previous day. Overcast may become dense.
 - B. Evidence of banding near the center ($< 1^\circ$ latitude)
4. ST 3.5 (55-65 knots)
 - A. Deep layer convection (frequently dense overcast) in band(s) $1^\circ-3^\circ$ latitude from the center (no central dense overcast).

Appendix C: Satellite Analysis Procedures in Operational Centers

- B. Outer convective band 5°-10° latitude to the east weaker than previous day, but new band may form 5°-10° latitude to the west.
- C. For systems moving rapidly eastward there may be only a dense overcast (=> 3° latitude) about 2°-4° latitude east of the center.

NOTE: In 3 and 4 if forward speed of the system at classification time exceeds 20 knots, the excess should be added to the maximum wind speed obtained by cloud feature criteria.

HP allows for a classification of ST1.5 or ST2.5 on the first day.

When applying the HP technique no restraints are imposed on intensity estimates (i.e., no development curve as in the Dvorak technique) other than the 24 hour trends in curvature, convection and organization of the system described in 1-4 above. **Therefore, limitations common to Dvorak such as maintaining current intensity for 12 hours when the system shows a trend toward weakening are not applicable to HP.**

There are no rules on when to switch from the HP technique to the Dvorak technique as a subtropical cyclone becomes tropical. Experience suggests the point when the Dvorak T-numbers become equal to the ST-numbers is a good time.

2.1.3.1 Assessing Subtropical Storm Intensity (i.e., wind speed)

Since the ST number is related solely to wind speed, a number of ancillary data sources can greatly assist the analyst in assigning an ST number in a more objective manner than described in the previous section. Keep in mind that unlike tropical cyclones which will have max winds near the center, subtropical cyclones will likely have the max winds at larger radii from the center. The following data sets, listed in order of priority, should be examined:

1. Ship and buoy reports

Type **SHIPP SPD <hh>** to overlay wind speeds on satellite imagery. See National Data Buoy Center on Internet through Tropical Hot List

2. Scatterometer (see Section 4 for details)

3. Microwave Data

- **BATCH <lat><lon><mag> AMSRWIN** *latest AMSR-E wind composite

ALT D will provide the wind speed in knots at the cursor location—just look for the SSW column in the output to the screen. To determine the max wind speed within the size of the cursor type: **IMGPROBE STAT BOX SSW** and the max wind speed will appear under the column marked MAX. The equator crossing time of each pass in the composite appears near/on the equator.

- **IMGDISP PLR/SSMIS08_WS 1 LATLON=XX YYY MAG=3**

This commands loads the latest SSMIS wind composite into frame 1. To determine the max wind speed within the size of the cursor type: **IMGPROBE STAT BOX WIND**.

- The NRL page also contains wind speed and direction from the WindSat sensor.

4. Schematics and photographs of ST number patterns in black binder as last resort.

2.1.3.2 Codifying Subtropical Storms

Appendix C: Satellite Analysis Procedures in Operational Centers

Unlike tropical classifications which roughly take the form **FT/CI/Trend**, subtropical classifications will simply be **ST#**--there will be no FT/CI or trend, but only a single number which relates to the current estimated wind speed (Table 2-1). Input this number as the CI in the GUI when running TDATA (see Section 4.4.1).

Dvorak	HP
T2.5/2.5/D1.0/24hrs	ST2.5
T2.5/3.5/W1.0/12hrs	ST2.5

Table 2-1 showing how to codify a subtropical classification compared to Dvorak.

Use the schematics and photographs of ST number patterns in the black binder to determine the PT. This PT should only be used when the various ancillary wind data sources fail to produce a clear cut or a timely (e.g., within last 6 hours) estimate of the current intensity.

2.2 Extratropical Transition

The Joint Typhoon Warning Center has found that “a significant number of cyclones that recurve and move out of the tropics are underestimated by satellite analysts using the Dvorak (1984) method to determine intensity.” As a result JTWC has developed a separate technique for systems undergoing extratropical transition. SAB has not incorporated this technique into our operations but will terminate support as soon as the extratropical transition begins as determined by JTWC’s guidelines. The factors listed below are to be used to determine if a system is transitioning or still tropical in nature.

1. Conditions in which to apply the Dvorak technique:
 - A. Decrease or partial loss of persistent central convection and system slows and dissipation begins.
 - B. Dissipation in shear type pattern and no acceleration.
2. Conditions in which to discontinue Dvorak technique:
 - A. Loss of half or more of the persistent central convection that surrounds the circulation center and system maintains forward motion or accelerates.
 - B. Interaction with other synoptic features such as a shear lines or baroclinic zones.

CIMSS’ AMSU Tropical Cyclone Page (see the Cold or Warm Core? link on the Tropical Hot List) can assist in ascertaining whether a system contains a warm core. Examine the channel 7 (200 mb) and 8 (100 mb) data for a warm core of brightness temperatures in the vicinity of the center as in the images below for Cyclone Nargis (2008).

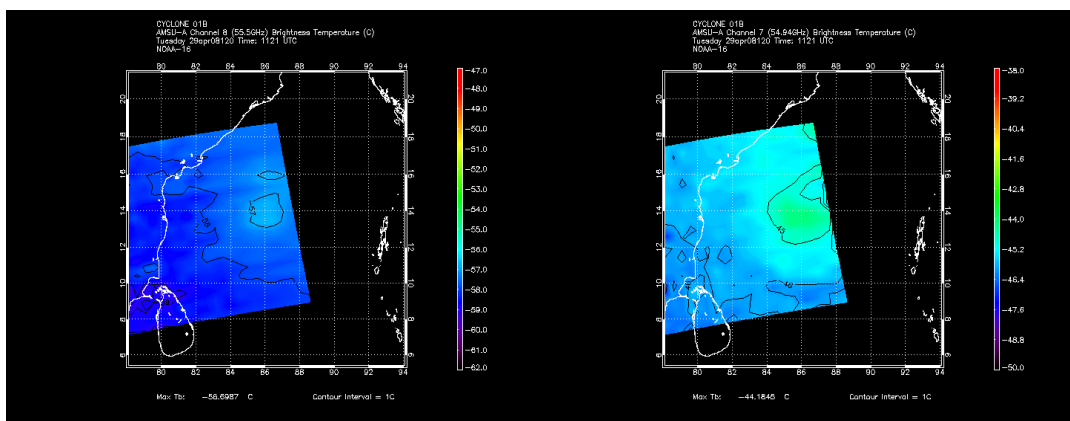

In major hurricanes and typhoons, the warm core will be well defined and tight in both

Appendix C: Satellite Analysis Procedures in Operational Centers

channels as in the images below for Supertyphoon Rammasun (2008).

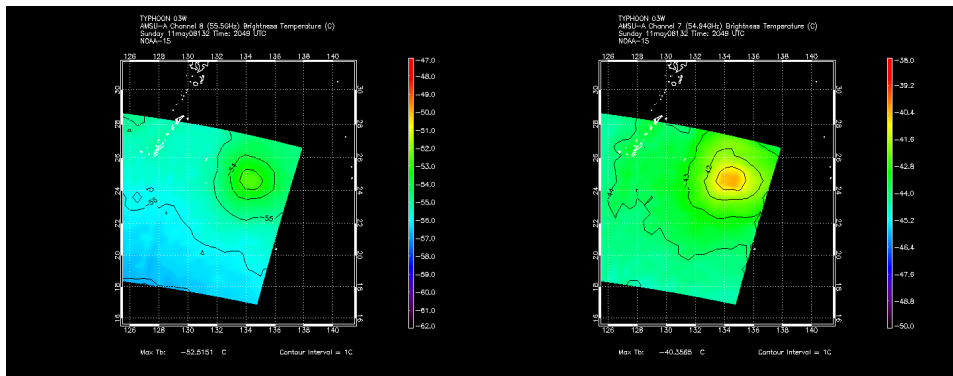

As extratropical transition occurs, the warm core is disrupted at 100 mb (Ch. 8) followed by 200 mb (Ch. 7) as exhibited in the images below of Rammasun (2008) as it underwent extratropical transition. At this point the analyst should classify the system as “becoming extratropical.”

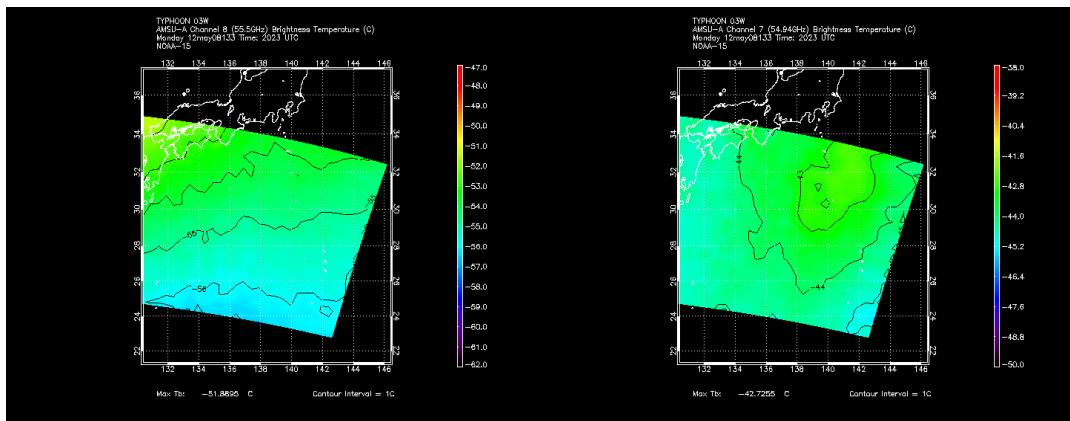

According to Roger Edson, loss of deep ice convection (seen in the 85 GHz) near the TC center and expansion of the winds away from the center and into a horseshoe-like appearance are some of the characteristics of extratropical transition in the microwave and scatterometer data (Figure 2-1).

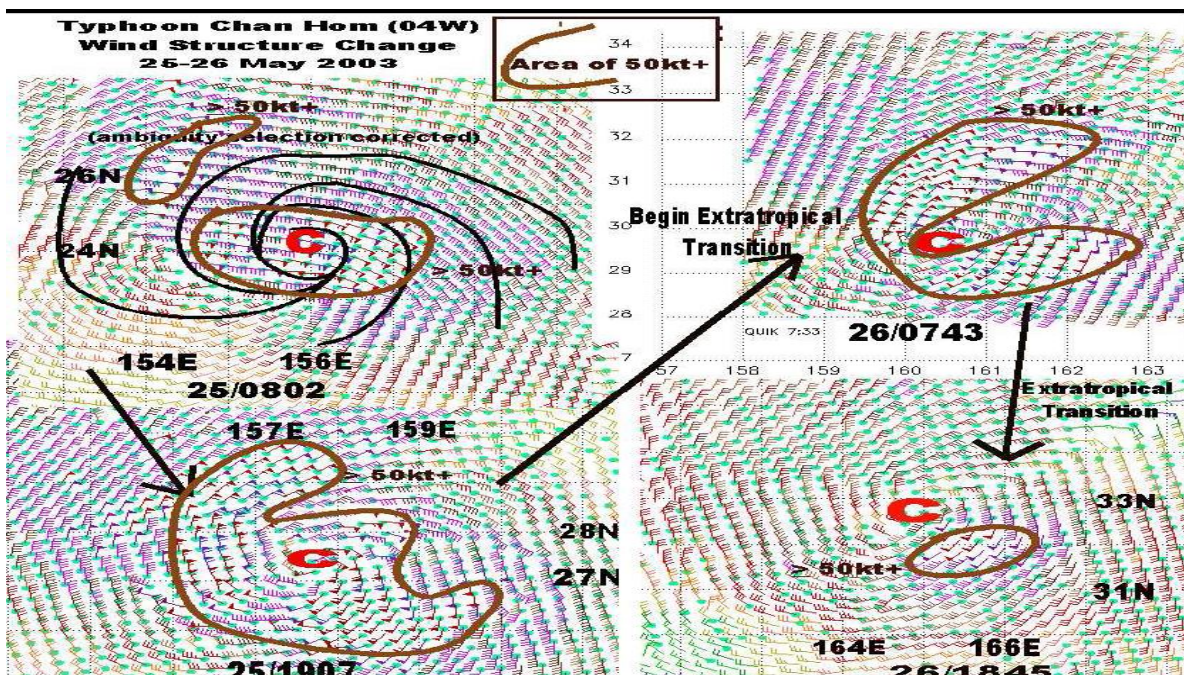
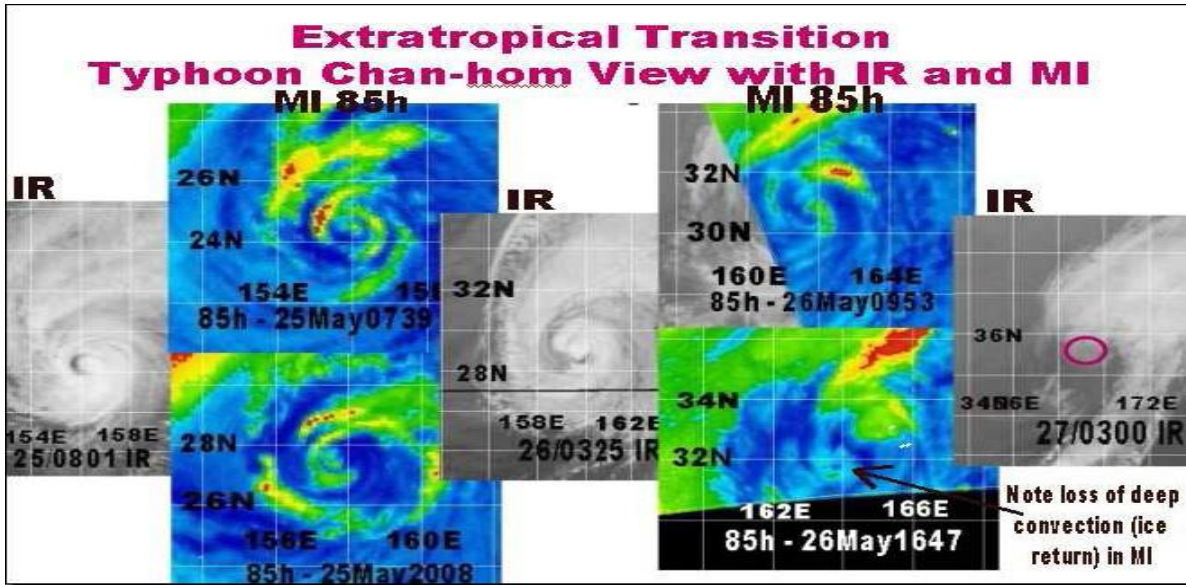

Figure 2-1 showing signals of extratropical transition in QSCAT (above) and MW imagery (below).



3. THE CLASSIFICATION PROCESS

Analysis Techniques

3.1 Determining Position

The purpose of this section is not to focus on conventional infrared (IR) and visible (VIS) geostationary satellite data, but rather to draw attention to ancillary satellite data and other techniques that can aid the analyst in determining the center location of a tropical cyclone.

The cloud system center (CSC) of a weak system is not always a closed circulation center. In a system with multiple centers, use a mean center position between the various centers.

3.1.1 Microwave Imagery

Perhaps the single most important ancillary data set for determining position, microwave (MW) imagery is useful in identifying low level circulation centers when conventional geostationary imagery is not helpful. The most recent viable microwave image for each active tropical cyclone and disturbance **must** be analyzed at the start of the classification process and the position estimate stored electronically using MIDATA (see end of this section). A viable microwave image is one that covers the center of the storm sufficiently to allow for analysis. Microwave analysis does **not** need to be performed when 1) an eye is apparent in either visible or conventional IR data at the classification time; 2) a MW fix cannot be determined accurately to within 40 nmi; or 3) the center of circulation is completely exposed in either visible or conventional IR data at classification time. Ideally all MW data within 90 minutes either side of classification time should be analyzed and corrections issued/made when MW analysis shows the center to be outside the analyst's stated PCN.

The Naval Research Laboratory (NRL) web page has the added benefit of providing a Satellite Pass Log for each system (Figure 3-1). This will indicate the times of viable (highlighted in green) MW and QuikSCAT data over the storm and can inform the analyst of whether MW imagery will be available within 90 minutes of classification time.

Appendix C: Satellite Analysis Procedures in Operational Centers

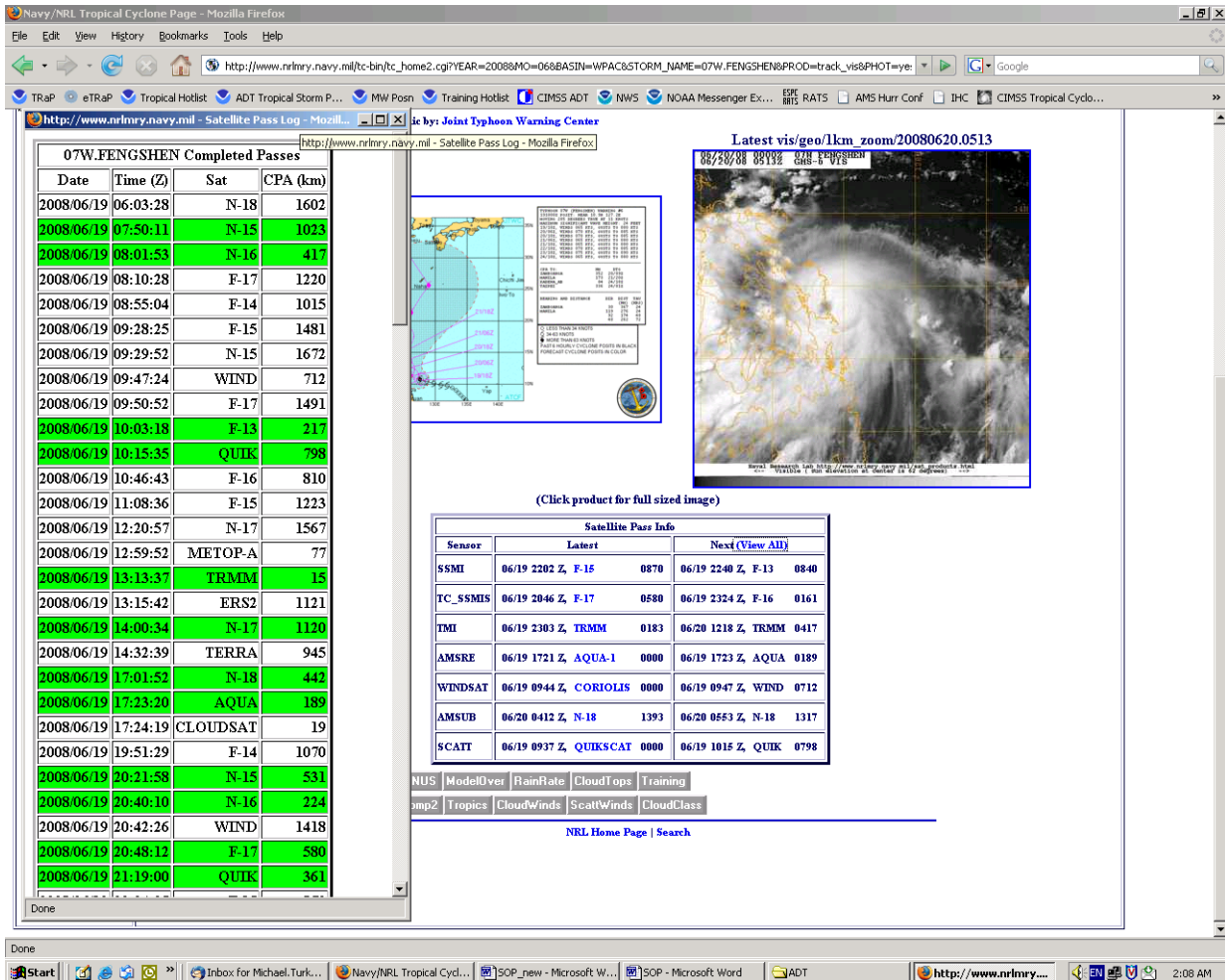

Figure 3-1 showing the Naval Research Laboratory's (NRL) web page and Satellite Pass Log on the left side of the screen. The Satellite Pass Log can be used by the analyst to quickly determine what viable (in green) MW imagery, if any, will be available within 90 minutes of classification time.

The following MW imagery is available in McIDAS:

- Defense Meteorological Satellite Program's (DMSP) Special Sensor Microwave Imager (SSM/I) 85 GHz data from F15.
- Advanced Microwave Sounding Unit (AMSU) 89 GHz data from NOAA POES N15 and N19 plus European Metop-A
- NASA Tropical Rainfall Measuring Mission (TRMM) 85 and 37 GHz microwave data
- Advanced Microwave Scanning Radiometer (AMSR-E) 89 and 36 GHz data from NASA EOS Aqua satellite
- DMSP Special Sensor Microwave Imager/Sounder (SSMIS) 37 and 91 GHz data from F16 and F17.

This data can be examined in McIDAS using the following commands:

BATCH [lat] [lon] [mag] MI89 loads all 85-91 GHz MW data
BATCH [lat] [lon] [mag] MI37 loads all 36-37 GHz MW data
BATCH [lat] [lon] [mag] LOOPSDR loads loop of 85 GHz SSM/I data

BATCH [lat] [lon] [mag] AMSULOOPSDR1 loads loop of 89 GHz AMSU data

Additional MW data that can only be found on the NRL or FNMOC web pages include:

- USN Coriolis WindSat 36 GHz microwave data

How to Interpret 85-91 GHz and 36-37 GHz Imagery (Courtesy of Roger Edson)

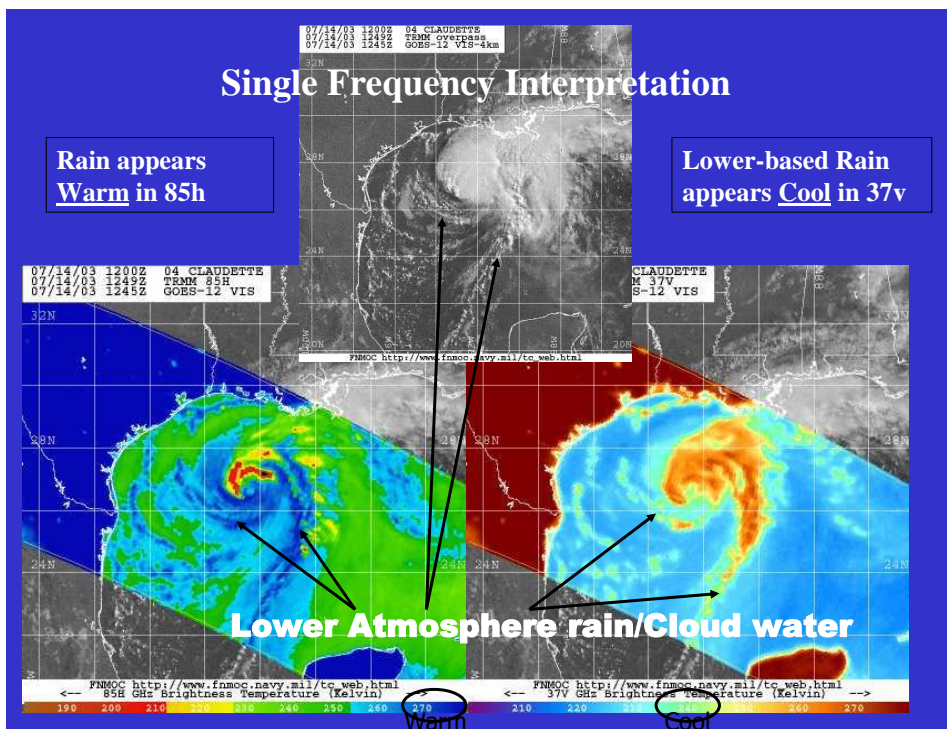
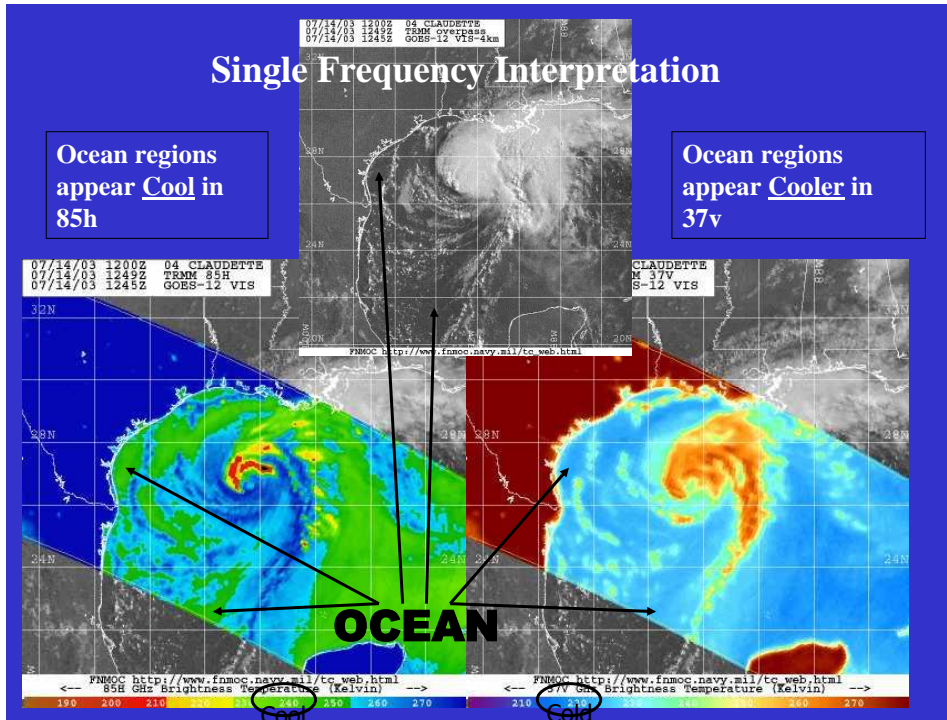

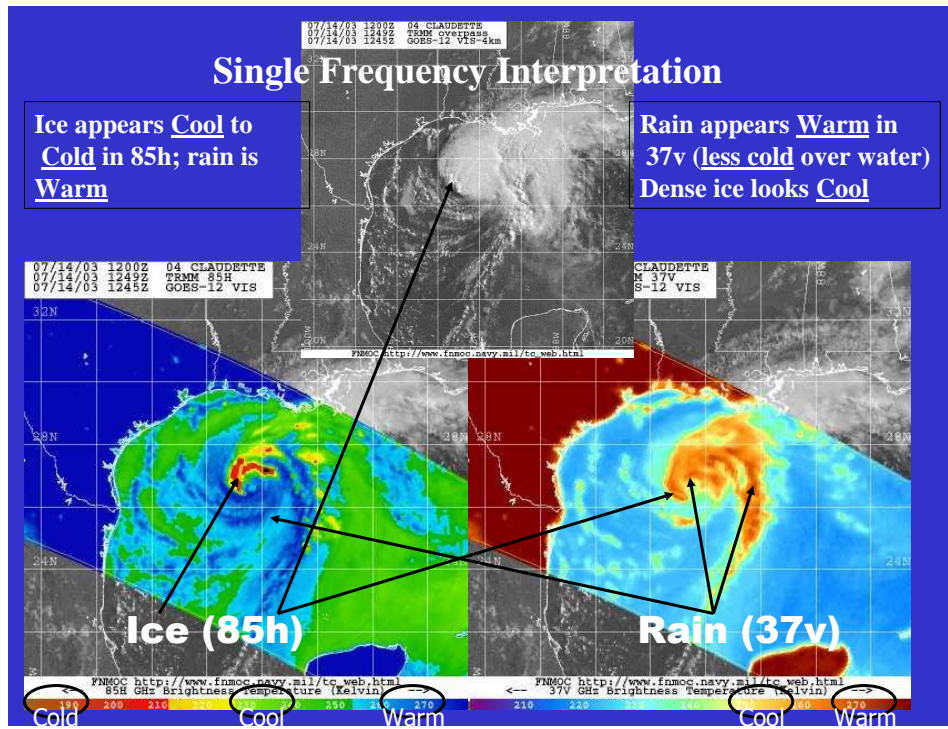

A note on parallax correction and its effect on positioning (Courtesy of Roger Edson)

Parallax viewing has an effect on the positioning of the centers of tropical cyclones. The diagram in Figure 3-2 isn't drawn to scale but gives an idea of this parallax offset. At 85 GHz the satellite views a feature composed of ice crystals high in the cloud system, apparently above point X. But because of the conical viewing angle, the satellite-derived position is displaced to point Y.

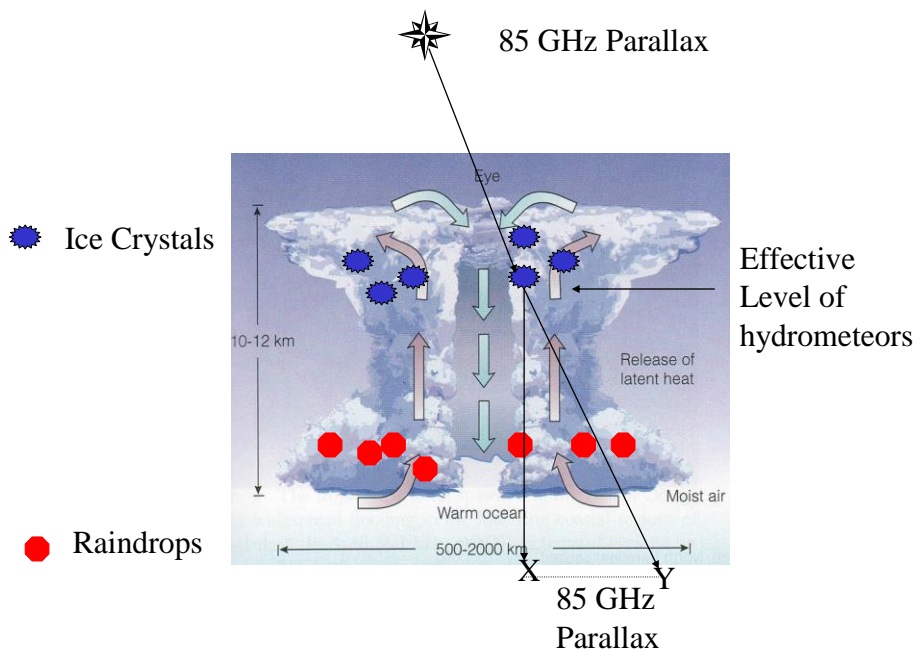

Figure 3-2 showing the 85 GHz parallax.

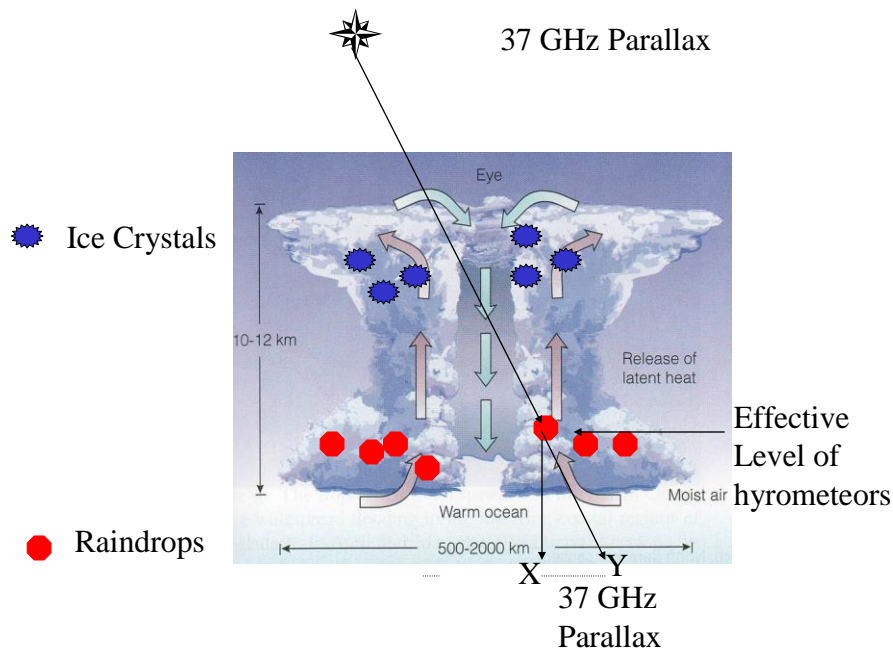

Figure 3-3 showing the 37 GHz parallax.

But at 37 GHz the rain feature sensed is much lower in the cloud. The displacement due to viewing geometry still occurs, but the displacement is less (Figure 3-3).

For instruction on interpreting MW data, the analyst is referred to the

- **Analysis Techniques Workbook** located in the tropical area
- The COMET module Polar Satellite Products for the Operational Forecaster: Microwave Analysis of Tropical Cyclones and Microwave Imagery Interpretation, links to which can be found under the New Employee Training section of the Training Hot List under Tropical Meteorology and Analysis

CTRL-P executed on SabTyphoon or SabHurricane will plot circles of radii with 10 nmi increments from 20 nmi to 60 nmi from the cursor location. Additional rings with radii of 75- and 100 nmi will also appear. If a position fix can be made confident to within 40 nmi, the analyst is to

- place a hard copy of the image in the storm folder on the right hand side with the position and the time written on it;
- indicate the data source on the Tropical Cyclone Analysis Worksheet under the column Other data sources;
- run MIDATA to send the fix to the web page and save it electronically to ensure that it is included in the bulletin.

When the microwave data proves useful to the analyst in either determining position or intensity a hard copy should be placed on the right hand side of the storm folder. A position should be attained (using the KML files on the NRL page, if not available in McIDAS) and the position and time should be noted on the hard copy. MIDATA should be run to save the fix electronically and to send it to the web.

3.1.2 Shortwave (SW) Infrared (IR) Imagery

The shortwave IR data is most useful in analyzing storms which are sheared. For a four image loop of re-mapped shortwave IR imagery enter the command

CHAN2 [lat] [lon] [sat]

where lat, lon are the latitude and longitude of the (approximate) storm center and sat is:

- 1 for GOES-E NH
- 11 for GOES-E SH
- 2 for GOES-W NH
- 22 for GOES-W SH
- 3 for MTSAT NH
- 33 for MTSAT SH
- 4 for FY-2D
- 5 for MET 7 and
- 8 for MET 9

CH2C and **CH2C1** are enhancements designed for use on shortwave imagery (EU REST CH2C LOOP=Y). When the SW IR data proves useful to the analyst in either determining position a hard copy should be placed on the right hand side of the storm folder.

3.1.3 Scatterometer Data

Data from the ASCAT instrument on EUMETSAT's MetOp satellite can be viewed by typing **ASCAT**. The swath is significantly smaller than QuikSCAT and the resolution is only 25 km. In spite of the smaller swath size, the wind speeds are more reliable in rain areas and at higher wind speeds.

Roger Edson provides the following guidelines on using scatterometer data (Figure 3-4 through 3-6). It is best to use scatterometer data in conjunction with other data (e.g., MW, track history) to corroborate the position. Trust the scatterometer data like any other piece of data: if it makes sense, use it. A weak system within the equatorial trough axis common in the Atlantic and South Indian oceans can result in an incorrect or no circulation center appearing in the scatterometer solution. In such situations the true position can be found by looking in lighter winds (near a trough axis), on the cyclonic side of the highest wind speeds (Figure 3-4). In performing this solution, avoid winds speeds that appear excessively enhanced by rain. This problem may also occur in small systems or when the equatorial westerlies are weak.

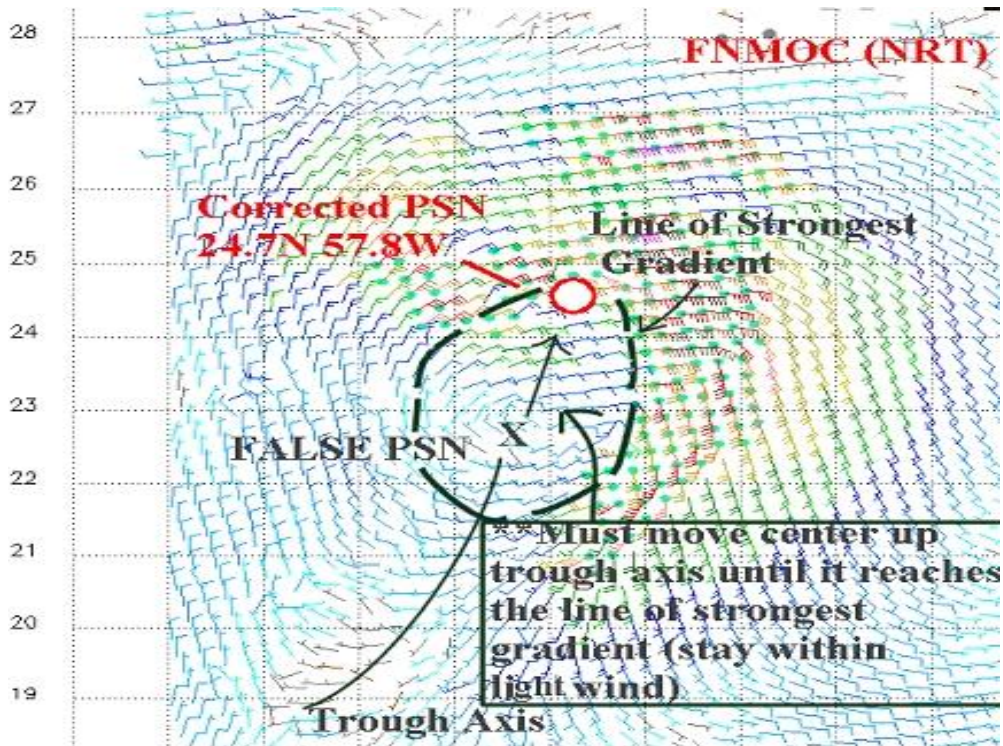

Figure 3-4 showing how to execute the “trough-axis” solution. The center should be placed within the light winds. (Figure courtesy of Roger Edson.)

A method of determining the position in scatterometer data is called the isotach solution (Figure 3-5). Examine the wind speeds in the approximate location of the center (based on MW imagery, continuity or forecast). Look for a potential center in the lightest winds that are in close proximity to the highest winds in the analysis. NOTE: This may not exist for very small circulation centers. When executing the isotach solution, the analyst should avoid wind speeds that appear excessively enhanced by rain.

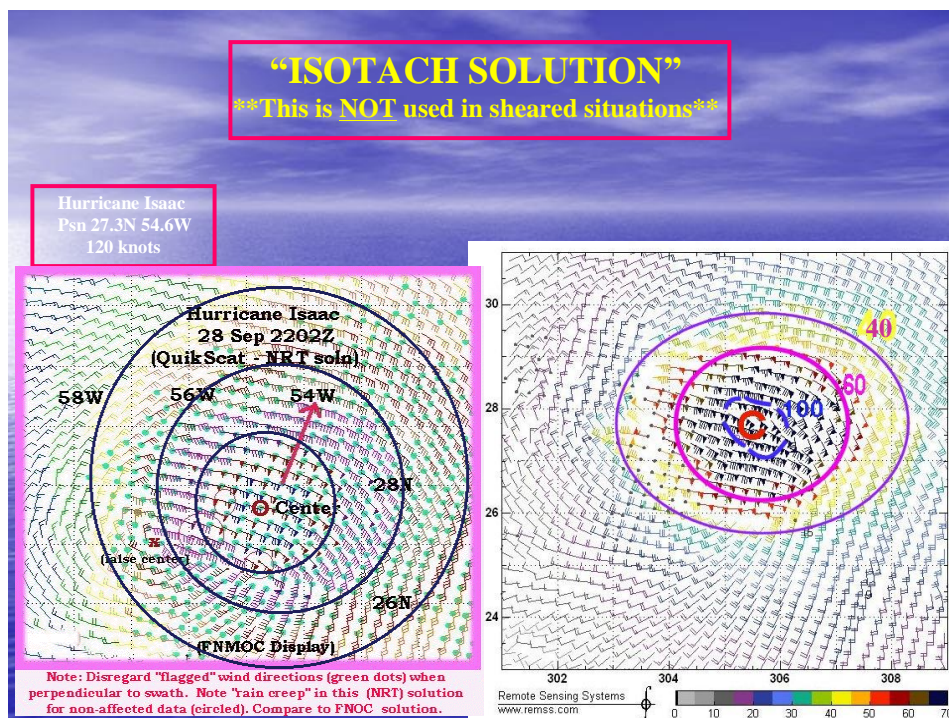

Figure 3-5 showing an example of the isotach solution. (Figure courtesy of Roger Edson.)

Heavy rain can weaken or eliminate the fore-view/aft-view signal differential necessary for direction determination resulting in an artificial rain-related equal-directional return that gives a solution that can only be in a cross-track wind direction, perpendicular to the swath (Figure 3-6). Views of the ambiguity plots often indicate alternate likely solutions in such cases.

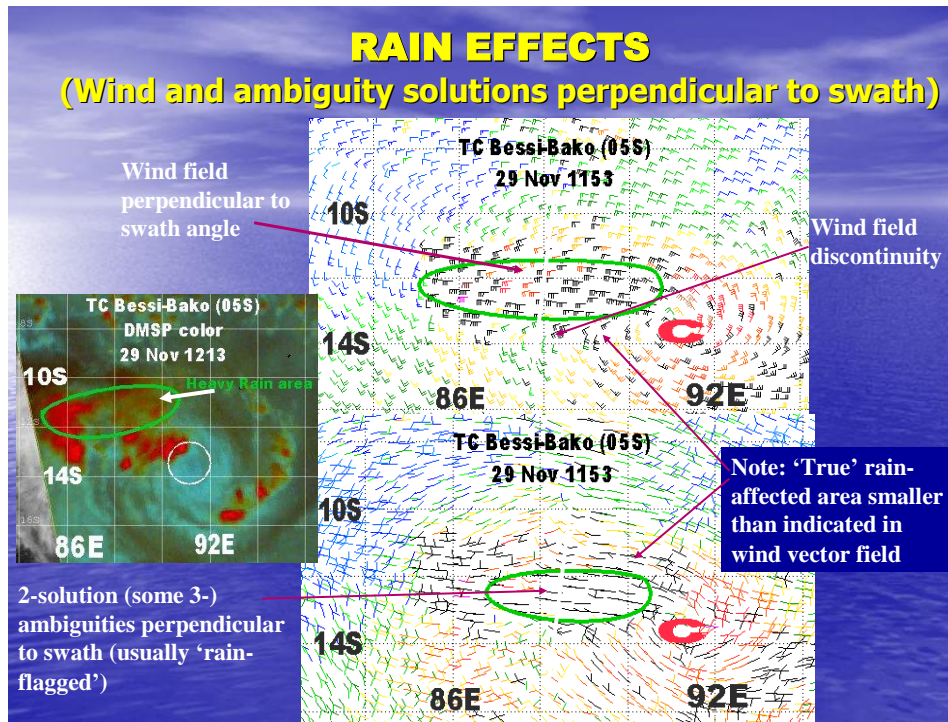

Figure 3-6 showing the effects of rain. (Figure courtesy of Roger Edson.)

When the ASCAT data proves useful to the analyst in either determining position or intensity a hard copy should be placed on the right hand side of the storm folder. A position should be attained (using calipers if taking the data from the internet) and the position and time should be noted on the hard copy. MIDATA should be run to save the fix electronically and to send it to the web.

The NRL page also contains wind speed and direction from the WindSat sensor.

3.1.4 HURRXRI (Plot Previous Positions)

To ensure that continuity is maintained with each classification the following command can be used to plot SAB Dvorak and microwave positions on top of satellite imagery:

HURRXRI <storm_id>

where storm_id is the alphanumeric used in conjunction with TDATA. See Appendix 8.5 for commands to plot forecast NHC and JTWC positions.

3.1.5 Advanced Dvorak Technique (ADT)

In addition to intensity, the ADT provides position estimates based on 1 of 4 methodologies: interpolation of the RSMC or JTWC forecast (FCST), spiral analysis (SPRL), a combination of spiral and ring analysis (COMBO) or extrapolation of the ADT history file (EXTRP). The tropical team's assessment of ADT positions found them to be accurate, on average, to within 30 nmi with every fix method except extrapolation. **ADT positions determined from extrapolation should not be used due to the large errors identified with this fix method.**

Appendix C: Satellite Analysis Procedures in Operational Centers

ADT data can be accessed from the Tropical Hot List at TC Analysis/Tools/CIMSS ADT. A sample of a storm's history file appears in Figure 3-7. The 4th, 3rd, and 2nd from the end columns provide the lat, lon and fix method, respectively.

==== ADT-Version 7.2.1 =====

Date	Time (UTC)	Final MSRP / BiasAdj (kts)	Intensity	Ave Ave Raw Raw	Tno Values	Tno/CI Rules	Temperature	Scene	EstRMW	Storm Location	Fix	Comments
2008JAN13	063000	1.5 1003.0	+0.0 / 25.0	1.5 1.5 1.5 1.5	NO LIMIT	OFF OFF	-1.76 -39.70	CRVBND	N/A	13.02 -118.03	FCST	
2008JAN13	073000	1.5 1003.0	+0.0 / 25.0	1.5 1.5 1.6 2.2	0.17/hour	OFF OFF	-6.14 -40.91	CRVBND	N/A	13.06 -117.89	FCST	
2008JAN13	083000	1.5 1003.0	+0.0 / 25.0	1.5 1.5 1.6 2.7	0.17/hour	OFF OFF	-24.00 -37.89	CRVBND	N/A	13.09 -117.76	FCST	
2008JAN13	093000	1.6 1002.4	+0.0 / 26.0	1.6 1.6 1.7 2.5	0.17/hour	OFF OFF	-33.05 -35.72	CRVBND	N/A	13.12 -117.62	FCST	
2008JAN13	103000	1.6 1002.4	+0.0 / 26.0	1.6 1.6 1.7 2.2	0.17/hour	OFF OFF	-2.28 -30.18	CRVBND	N/A	13.15 -117.49	FCST	
2008JAN13	113000	1.6 1002.4	+0.0 / 26.0	1.6 1.7 1.8 2.2	0.17/hour	OFF OFF	7.59 -24.72	CRVBND	N/A	13.17 -117.35	FCST	
2008JAN13	123000	1.7 1001.8	+0.0 / 27.0	1.7 1.7 1.8 2.7	0.17/hour	OFF OFF	-28.56 -34.16	CRVBND	N/A	13.41 -117.12	FCST	
2008JAN13	133000	1.8 1001.2	+0.0 / 28.0	1.8 1.8 2.1 2.7	0.57/hour	OFF OFF	-28.01 -33.44	CRVBND	N/A	13.42 -116.97	FCST	
2008JAN13	143000	1.9 1000.6	+0.0 / 29.0	1.9 2.0 2.2 2.5	0.77/6hr	OFF OFF	-21.16 -32.31	CRVBND	N/A	13.43 -116.82	FCST	
2008JAN13	153000	2.0 1000.0	+0.0 / 30.0	2.0 2.0 2.3 2.5	0.57/hour	OFF OFF	5.22 -27.87	CRVBND	N/A	13.44 -116.67	FCST	
2008JAN13	163000	2.1 999.4	+0.0 / 31.0	2.1 2.2 2.3 2.5	0.77/6hr	OFF OFF	-13.53 -27.70	CRVBND	N/A	13.45 -116.53	FCST	
2008JAN13	173000	2.2 998.8	+0.0 / 32.0	2.2 2.2 2.3 2.7	0.77/6hr	OFF OFF	-14.72 -29.98	CRVBND	N/A	13.45 -116.38	FCST	
2008JAN13	183000	2.3 998.2	+0.0 / 33.0	2.3 2.3 2.4 3.0	0.77/6hr	OFF OFF	-46.81 -36.15	CRVBND	N/A	13.31 -115.90	FCST	
2008JAN13	193000	2.3 998.2	+0.0 / 33.0	2.3 2.3 2.5 3.2	0.77/6hr	OFF OFF	-52.93 -38.97	CRVBND	N/A	13.31 -115.70	FCST	
2008JAN13	203000	2.4 997.6	+0.0 / 34.0	2.4 2.4 2.6 3.0	0.77/6hr	OFF OFF	-55.41 -41.31	CRVBND	N/A	13.32 -115.51	FCST	
2008JAN13	213000	2.5 997.0	+0.0 / 35.0	2.5 2.5 2.7 3.0	0.77/6hr	OFF OFF	-48.28 -44.24	CRVBND	N/A	13.32 -115.32	FCST	
2008JAN13	223000	2.5 997.0	+0.0 / 35.0	2.4 2.5 2.2 2.2	NO LIMIT	ON OFF	-42.84 -42.73	CRVBND	N/A	13.32 -115.13	FCST	
2008JAN13	233000	2.5 997.0	+0.0 / 35.0	2.5 2.5 2.7 2.7	NO LIMIT	OFF OFF	-36.22 -38.27	CRVBND	N/A	13.32 -114.94	FCST	
2008JAN14	003000	2.6 995.8	+0.0 / 37.0	2.6 2.6 2.9 3.2	0.57/hour	OFF OFF	-53.47 -42.50	CRVBND	N/A	12.77 -114.81	FCST	
2008JAN14	013000	2.7 994.6	+0.0 / 39.0	2.7 2.7 3.0 3.2	0.77/6hr	OFF OFF	-49.78 -45.18	CRVBND	N/A	12.72 -114.64	FCST	
2008JAN14	023000	2.8 993.4	+0.0 / 41.0	2.8 2.9 3.0 3.0	NO LIMIT	OFF OFF	-46.81 -45.01	CRVBND	N/A	12.66 -114.47	FCST	
2008JAN14	033000	2.8 993.4	+0.0 / 41.0	2.7 2.8 2.5 2.5	NO LIMIT	ON OFF	-22.65 -43.17	CRVBND	N/A	12.60 -114.30	FCST	
2008JAN14	043000	2.8 993.4	+0.0 / 41.0	2.7 2.7 2.5 2.5	NO LIMIT	ON OFF	-22.98 -42.23	CRVBND	N/A	12.54 -114.13	FCST	
2008JAN14	053000	2.8 993.4	+0.0 / 41.0	2.5 2.4 2.2 2.2	NO LIMIT	ON FLG	-24.85 -45.05	CRVBND	N/A	12.47 -113.96	FCST	
2008JAN14	063000	2.8 993.4	+0.0 / 41.0	2.6 2.6 3.2 3.2	NO LIMIT	ON OFF	-48.78 -49.16	CRVBND	N/A	12.36 -113.60	FCST	
2008JAN14	073000	2.8 993.4	+0.0 / 41.0	2.7 2.7 3.0 3.0	NO LIMIT	ON OFF	-24.67 -45.84	CRVBND	N/A	12.28 -113.39	FCST	
2008JAN14	083000	2.8 993.4	+0.0 / 41.0	2.8 2.8 3.1 3.2	0.57/hour	OFF OFF	-25.54 -47.56	CRVBND	N/A	12.20 -113.19	FCST	
2008JAN14	093000	3.0 991.0	+0.0 / 45.0	3.0 3.1 3.2 3.2	NO LIMIT	OFF OFF	-55.98 -43.34	CRVBND	N/A	12.12 -112.99	FCST	
2008JAN14	103000	3.0 991.0	+0.0 / 45.0	3.0 3.0 3.0 3.0	NO LIMIT	OFF OFF	-28.01 -40.21	CRVBND	N/A	12.03 -112.79	FCST	
2008JAN14	113000	3.1 989.6	+0.0 / 47.0	3.1 3.1 3.2 3.5	0.77/6hr	OFF OFF	-57.13 -35.79	CRVBND	N/A	11.95 -112.60	FCST	
2008JAN14	123000	3.1 989.6	+0.0 / 47.0	3.0 3.0 2.7 2.7	NO LIMIT	ON OFF	-26.76 -35.10	CRVBND	N/A	11.73 -112.72	FCST	
2008JAN14	133000	3.1 989.6	+0.0 / 47.0	2.8 2.8 2.6 2.5	0.57/hour	ON OFF	-9.05 -33.98	CRVBND	N/A	11.59 -112.55	FCST	
2008JAN14	143000	3.1 989.6	+0.0 / 47.0	2.7 2.5 2.5 2.5	NO LIMIT	ON FLG	-11.47 -25.68	CRVBND	N/A	11.45 -112.39	FCST	
2008JAN14	153000	3.1 989.6	+0.0 / 47.0	2.5 2.5 2.3 2.2	0.77/6hr	ON FLG	-14.27 -18.28	CRVBND	N/A	11.32 -112.23	FCST	
2008JAN14	163000	3.1 989.6	+0.0 / 47.0	2.7 2.6 3.2 3.2	NO LIMIT	ON OFF	0.66 -20.23	SHEAR	N/A	11.19 -112.08	FCST	
2008JAN14	173000	3.0 991.0	+0.0 / 45.0	2.7 2.7 3.0 3.1	0.57/hour	ON OFF	11.74 -23.22	SHEAR	N/A	11.06 -111.93	FCST	
2008JAN14	183000	3.0 991.0	+0.0 / 45.0	2.7 2.7 2.5 2.5	NO LIMIT	ON OFF	13.96 -29.31	CRVBND	N/A	10.95 -112.02	FCST	
2008JAN14	193000	2.8 993.4	+0.0 / 41.0	2.5 2.7 2.2 2.2	NO LIMIT	ON OFF	7.59 -28.59	CRVBND	N/A	10.84 -111.87	FCST	
2008JAN14	203000	2.7 994.6	+0.0 / 39.0	2.6 2.6 2.7 2.7	NO LIMIT	ON OFF	6.53 -37.34	CRVBND	N/A	10.73 -111.72	FCST	
2008JAN14	213000	2.7 994.6	+0.0 / 39.0	2.4 2.4 2.2 2.2	NO LIMIT	ON OFF	3.16 -37.58	CRVBND	N/A	10.63 -111.57	FCST	
2008JAN14	223000	2.7 994.6	+0.0 / 39.0	2.4 2.4 2.5 2.5	NO LIMIT	ON FLG	3.65 -35.55	CRVBND	N/A	10.53 -111.43	FCST	
2008JAN14	233000	2.7 994.6	+0.0 / 39.0	2.5 2.5 2.9 3.0	0.57/hour	ON OFF	-30.39 -46.08	CRVBND	N/A	10.43 -111.28	FCST	
2008JAN15	003000	2.6 995.8	+0.0 / 37.0	2.6 2.7 2.9 3.9	0.57/hour	ON OFF	-62.35 -54.52	CRVBND	N/A	10.33 -111.14	FCST	
2008JAN15	013000	2.7 994.6	+0.0 / 39.0	2.7 2.8 3.0 3.1	0.57/hour	OFF OFF	17.11 -16.71	SHEAR	N/A	9.32 -111.52	FCST	
2008JAN15	023000	2.7 994.6	+0.0 / 39.0	2.7 2.8 2.4 2.4	NO LIMIT	OFF OFF	18.81 -4.80	SHEAR	N/A	9.21 -111.41	FCST	
2008JAN15	033000	2.7 994.6	+0.0 / 39.0	2.5 2.6 2.2 2.2	NO LIMIT	ON OFF	16.04 0.79	SHEAR	N/A	9.09 -111.29	FCST	
2008JAN15	043000	2.7 994.6	+0.0 / 39.0	2.7 2.7 3.2 3.3	0.57/hour	OFF OFF	18.49 2.45	SHEAR	N/A	8.98 -111.18	FCST	
2008JAN15	053000	2.7 994.6	+0.0 / 39.0	2.6 2.5 2.3 2.3	NO LIMIT	ON OFF	18.07 2.80	SHEAR	N/A	8.86 -111.06	FCST	

Figure 3-7 showing an ADT history file from the CIMSS ADT website. The 4th, 3rd, and 2nd from the end columns provide the lat, lon and fix method, respectively.

3.2 Determining Intensity

The purpose of this section is not to focus on conventional infrared (IR) and visible (VIS) geostationary satellite data, but rather to draw attention to ancillary satellite data and other techniques that can aid the analyst in determining the intensity a tropical cyclone.

3.2.1 Satellite Consensus (SATCON) Estimates (formerly CIMSS AMSU)

The CIMSS Satellite Consensus (SatCon) product blends tropical cyclone intensity estimates derived from multiple objective algorithms to produce an ensemble estimate of intensity for current tropical cyclones worldwide. The SatCon algorithm uses individual ADT, CIMSS AMSU, and CIRA AMSU intensity estimates utilizing a statistically-derived weighting scheme which maximizes/minimizes the strength/weaknesses of each technique to produce a consensus estimate of the current tropical cyclone intensity. The tropical team's validation has shown the SatCon estimate to be superior to SAB's subjective estimates. The SatCon estimates are received in the Shift Supervisor's E-mail account. An example follows:

Experimental Objective Satellite Consensus (SATCON) TC Intensity Estimate
 Provider: UWisc - CIMSS
 TROPICAL CYCLONE 06W
 04 UTC 0531 2008

Appendix C: Satellite Analysis Procedures in Operational Centers

Latitude: 18.8N Longitude: 132.9E

| **Estimated MSLP: 946 hPa**
| Estimated Maximum Sustained Wind: 106 kts
Weights MSLP(MSW): ADT 15.6% CIMSS AMSU 52.6% CIRA AMSU 31.9%

SATCON MEMBER INFORMATION

ADT: 0430 UTC
Raw MSLP: 979 hPa MSW: 65 kts
Adjusted MSLP: 971 hPa MSW: 84 kts
Scene: UNIFRM Fix Method: SPRL Tno: 3.5 CI: 4.0

AMSU INFORMATION
Satellite: NOAA-18 0420 UTC

CIMSS AMSU
MSLP: 945 hPa MSW: 108 kts
RMW: 46 km (JTWC) FOV: 10 BIAS CORRECTION: 0 hPa
Environmental Pressure: 1008 hPa
ch7 anomaly: 4.92 K
ch8 anomaly: 4.20 K

CIRA AMSU
Raw MSLP: 937 hPa MSW: 113 kts
Adjusted MSLP: 934 hPa MSW: 114 kts
AMSU FOV Resolution: 55.7 km Tmax: 5.9

Notes: MSW is a 1-minute avg and includes motion component. Weights applied to adjusted estimates

The analyst should take note of the estimated MSLP (bolded in the example above) which should then be converted to a T-number using the P/T-number conversion chart posted to the board in the tropical work area. Systems in the Atlantic, East Pacific, Southeast Pacific and Central Pacific Basins should follow the conversion for MSLP (Atlantic). All others should use MSLP (NW Pacific).

The derived T-number is to be written in the CIMSS AMSU (T#) column on the Tropical Cyclone Analysis Worksheet. Based on SAB's validation for 2003-2008, SatCon intensity estimates almost always outperform SAB's subjective estimates, but they should be used cautiously when the TC eye is smaller than the AMSU-A FOV. NOTE: When the RMW, a proxy for the eye size, is smaller than the FOV, the warm core will be sub-sampled and bias correction is applied. The objective estimate should be given equal weighting with the DT, MET and PT when determining the subjective CI number.

3.2.2 Advanced Dvorak Technique (ADT)

The ADT CI number can be used when the DT, MET and PT are variable and a CIMSS AMSU intensity estimate isn't available. Include the ADT CI number in the ADT column on the Tropical Cyclone Analysis Worksheet.

Examination of the ADT raw T-number, Ini Raw in Figure 3-7, can signal extreme rapid intensification requiring suspension of Dvorak rules. The analyst may break the Dvorak rules when the average ADT raw T-number over the 6 hour period leading up to and including the current

classification time breaks constraints provided that the eye is resolved by the algorithm. In this situation the Tropical Cyclone Analysis Worksheet should indicate the subjective DT is based on the 6-hour average ADT. It should be noted in any bulletin that is disseminated.

3.2.3 Microwave Imagery

Since intensity is dependent on position in several Dvorak pattern types it stands to reason that MW imagery can be useful in assessing intensity. Experience has shown that:

- Banding type eyes appear in MW imagery at a CI of 3.0
- Bona fide eyes appear in MW imagery at a CI of 3.5 and greater.
- **BATCH <lat><lon><mag> AMSRWIN** *latest AMSR-E wind composite

ALT D will provide the wind speed in knots at the cursor location—just look for the SSW column in the output to the screen. To determine the max wind speed within the size of the cursor type: **IMGPROBE STAT BOX SSW** and the max wind speed will appear under the column marked MAX. The equator crossing time of each pass in the composite appears near/on the equator.

- **IMGDISP PLR/SSMIS08_WS 1 LATLON=XX YYY MAG=3**

This command loads the latest SSMIS wind composite into frame 1. To determine the max wind speed within the size of the cursor type: **IMGPROBE STAT BOX WIND**.

- The NRL page also contains wind speed and direction from the WindSat sensor.

Section 8.9 provides MW patterns associated with CI of 1.5 – 7.0.

3.2.4 Scatterometer Data

Data from the ASCAT instrument on EUMETSAT's MetOp satellite can be viewed by typing **ASCAT**. Scatterometer data should not be used to assess intensity in hurricanes—the winds depicted by the scatterometer will never achieve the current intensity. Scatterometer data has its greatest utility from the tropical disturbance stage through tropical storm (60 knots). Some rules of thumb:

- one needs to adjust winds UP in a progressive manner once the actual winds reach 'somewhere' between 20-25kt
- ASCAT 25kt are more likely (amount of rain in the column WILL affect this) 30-35kt
- ASCAT 35kt are more likely 45-50kt+
- winds >40-50kt only reflect a 'minimum' intensity (i.e., at least this value...or sometimes much greater)

Effects of Rain upon Scatterometer Data (Courtesy of Roger Edson)

Rain results in the attenuation of the up/down 13.4 GHz signal which reduces the wind speed estimate while simultaneously distorting the Bragg Waves on the ocean surface which can cause an "artificial" high estimate of winds in light to medium wind speed regions.

Comparison measurements from winds from hurricanes (by ship, buoy, or aircraft-based observations) indicate that **wind speeds are more likely to be low in true winds above 30-40 knots** (Edson et al., 2000). Heavy rain may be artificially increasing the signal in light wind regions.

3.2.5 Polar IR Data

For small eyes (generally less than 10 n mi wide), the satellite may not be able to measure the

warmest temperature at the bottom of the eye (Figure 3-8). The same can be said, even with larger eyes, when the tropical cyclone is on the edge of the satellite's field of view or when the tropical cyclone is located in the middle latitudes.

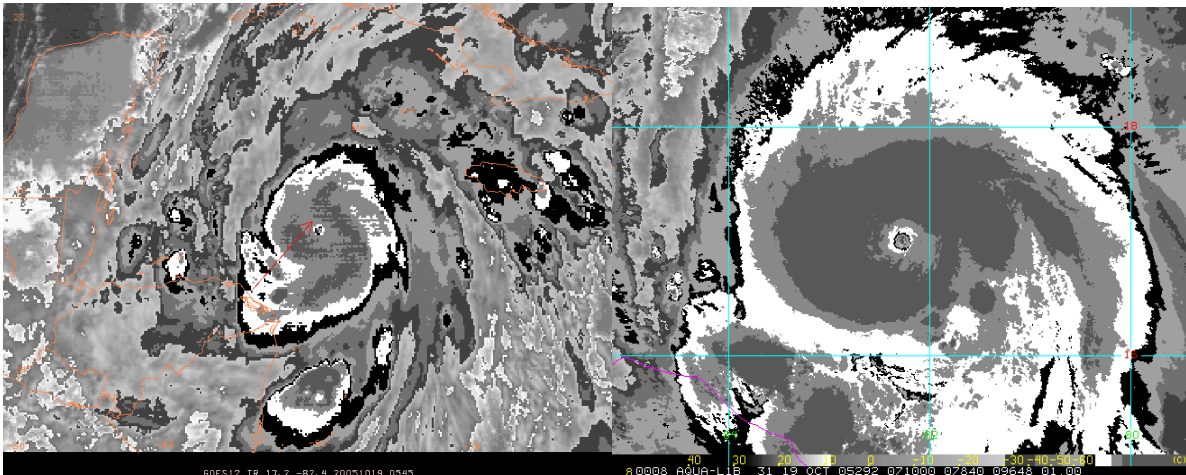

Figure 3-8 showing the 4 nmi wide eye of Hurricane Wilma on 19 October 2005 in GOES 12 imagery (left) at 0545Z with an eye temperature of approximately 0°C and in MODIS Aqua at approximately 0710Z with an eye temperature of approximately 20°C.

This can result in an underestimate of the intensity in both subjective Dvorak and objective (eg, ADT, SATCON) techniques. To prevent this, higher resolution polar IR data should be examined. The following batch commands will load the POES and MODIS data, respectively:

```
BATCH [lat] [lon] PLRTCIR.BAT  
BATCH [lat] [lon] MODISTCIR.BAT
```

It may not be possible to digitally interrogate (i.e., IMGPROBE via CTRL-F11) the eye temperature from the output of the batch commands and the analyst may have to ascertain the gray shade of the eye by sight. See Section 8.9 for instructions on how to load interrogable MODIS imagery. The gray shade of the eye in the polar data should be compared with that of the geostationary data at approximately the same time to determine how well the lower resolution geostationary data is performing in accurately assessing the eye temperature. This knowledge should then be considered at the current classification time.